

功能

新型塑料制集分水箱专为分体式及一体式集分水器设计，便于各类区域阀的配套安装。

箱体盖板上有特制通风口，防止箱体内温度过热。通风口特殊设计避免了热空气在墙壁上留下污渍。

塑料盖板表面易于喷涂为与室内装饰配套的颜色。



产品范围

362036型 塑料制集分水箱	尺寸270×360mm，深度80/100mm
362056型 塑料制集分水箱	尺寸330×560mm，深度80/100mm
362073型 塑料制集分水箱	尺寸360×730mm，深度80/100mm
363036型 塑料制集分水框	尺寸270×360mm
363056型 塑料制集分水框	尺寸330×560mm
363073型 塑料制集分水框	尺寸360×730mm



360001型 分水器固定支架
适合于350和592分水器3/4" -1" 型号
包装内为2个长支架和2个短支架

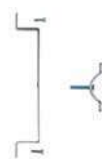



362001型 分水器固定架
适合于356、357及640型集分水器



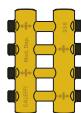
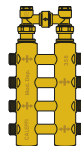
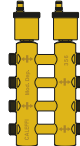
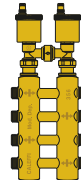

360002型 分水器固定支架
适合于349分水器3/4" 型号
包装内为2个长支架和2个短支架

356型集分水器与配套箱体的选择

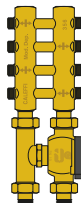
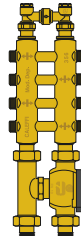
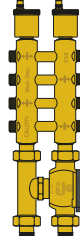
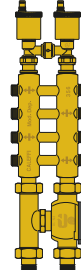
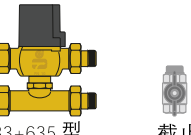

配套									
 356050型 5020型									
 截止阀									
编号	尺寸	3/4"	1"	3/4"	1"	3/4"	1"	3/4"	1"
362036 - 363036	270 x 360 mm	6+6	6+6	4+4	-	4+4	4+4	4+4	
362056 - 363056	330 x 560 mm	10+10	12+12	10+10	-	10+10	10+10	10+10	
362073 - 363073	360 x 730 mm	10+10	12+12	10+10	-	10+10	12+12	10+10	

配套									
 356050型 5020型									
 633+635型 截止阀									
编号	尺寸	3/4"	1"	3/4"	1"	3/4"	1"	3/4"	1"
362036 - 363036	270 x 360 mm	2+2	2+2	2+2	-	-	-	-	
362056 - 363056	330 x 560 mm	8+8	8+8	8+8	-	6+6	6+6	6+6	
362073 - 363073	360 x 730 mm	10+10	12+12	10+10	-	10+10	10+10	10+10	

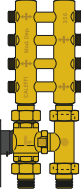
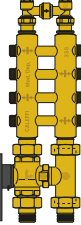
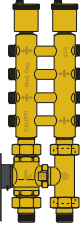
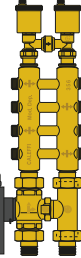
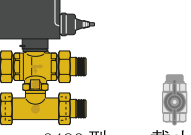
配套									
 356050型 5020型									
 6480+6490型 截止阀									
编号	尺寸	3/4"	1"	3/4"	1"	3/4"	1"	3/4"	1"
362036 - 363036	270 x 360 mm	2+2	-	2+2	-	2+2	2+2	-	
362056 - 363056	330 x 560 mm	10+10	8+8	8+8	-	8+8	6+6	6+6	
362073 - 363073	360 x 730 mm	10+10	12+12	10+10	-	10+10	10+10	10+10	

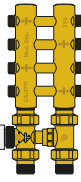
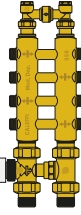
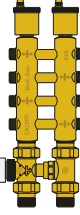
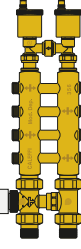
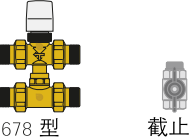
配套									
 356050型 5020型									
 678型 截止阀									
编号	尺寸	3/4"	1"	3/4"	1"	3/4"	1"	3/4"	1"
362036 - 363036	270 x 360 mm	4+4	4+4	2+2	-	2+2	2+2	-	
362056 - 363056	330 x 560 mm	10+10	10+10	8+8	-	8+8	8+8	6+6	
362073 - 363073	360 x 730 mm	10+10	12+12	10+10	-	10+10	10+10	10+10	

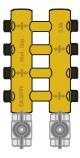
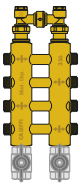
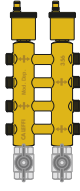
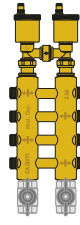
								
1"	3/4"	1"	3/4"	1"	3/4"	1"	3/4"	1"
-	4+4	4+4	2+2	-	2+2	-	-	-
-	10+10	10+10	8+8	-	8+8	8+8	6+6	-
-	10+10	12+12	10+10	-	10+10	10+10	10+10	-

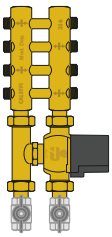
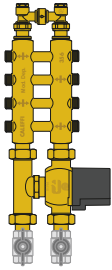
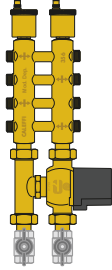
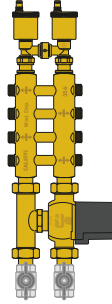

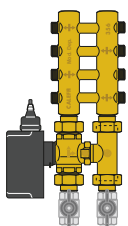
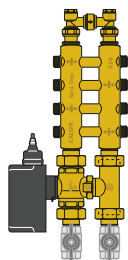
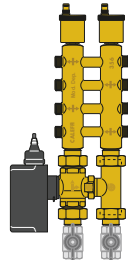
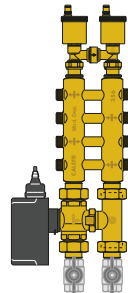
								
1"	3/4"	1"	3/4"	1"	3/4"	1"	3/4"	1"
-	2+2	2+2	-	-	-	-	-	-
-	8+8	8+8	6+6	-	6+6	4+4	4+4	-
-	10+10	10+10	10+10	-	10+10	8+8	8+8	-

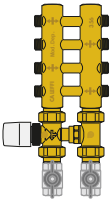
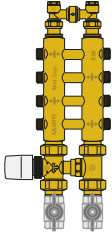
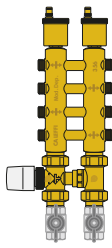
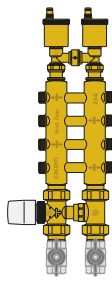

								
1"	3/4"	1"	3/4"	1"	3/4"	1"	3/4"	1"
-	2+2	2+2	-	-	-	-	-	-
-	8+8	8+8	6+6	-	6+6	4+4	4+4	4+4
-	10+10	10+10	10+10	-	10+10	8+8	8+8	8+8



								
1"	3/4"	1"	3/4"	1"	3/4"	1"	3/4"	1"
-	2+2	2+2	2+2	-	-	-	-	-
-	10+10	8+8	6+6	-	6+6	6+6	4+4	-
-	10+10	10+10	10+10	-	10+10	10+10	10+10	-

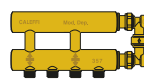
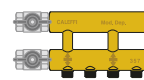
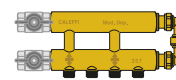

357型集分水器与配套箱体的选择

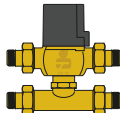
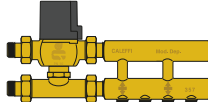
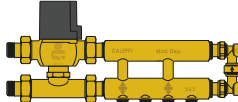
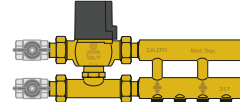
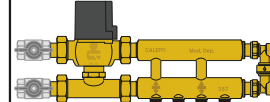

配套					
 356050 型  截止阀					
编号	尺寸	3/4"	3/4"	3/4"	3/4"
362036-363036	270 x 360 mm	3+3	2+2	2+2	-
362056-363056	330 x 560 mm	6+6	5+5	5+5	4+4
362073-363073	360 x 730 mm	-	6+6	6+6	6+6

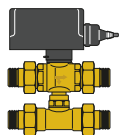
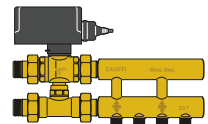
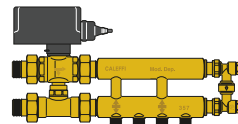
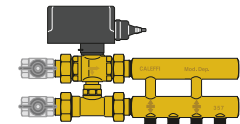
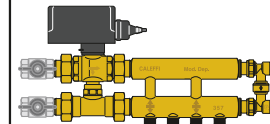
配套					
 356050 型  截止阀  633 + 635 型					
编号	尺寸	3/4"	3/4"	3/4"	3/4"
362036-363036	270 x 360 mm	-	-	-	-
362056-363056	330 x 560 mm	4+4	4+4	3+3	3+3
362073-363073	360 x 730 mm	6+6	6+6	5+5	5+5

配套					
 356050 型  截止阀  648950 型					
编号	尺寸	3/4"	3/4"	3/4"	3/4"
362036-363036	270 x 360 mm	2+2	-	2+2	-
362056-363056	330 x 560 mm	4+4	4+4	4+4	3+3
362073-363073	360 x 730 mm	6+6	6+6	6+6	6+6

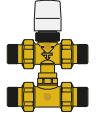
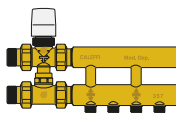
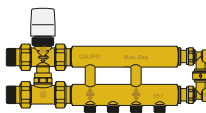
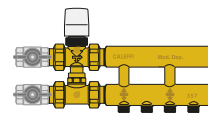
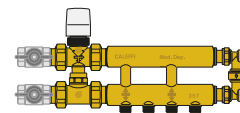
配套					
 356050 型  截止阀  678 型					
编号	尺寸	3/4"	3/4"	3/4"	3/4"
362036-363036	270 x 360 mm	4+4	2+2	2+2	-
362056-363056	330 x 560 mm	5+5	4+4	5+5	4+4
362073-363073	360 x 730 mm	6+6	6+6	6+6	6+6

350型和592型分水器与配套箱体的选择



. Numero massimo di derivazioni.

配套									
5020 型	截止阀								
编号	尺寸	3/4"	1"	3/4"	1"	3/4"	1"	3/4"	1"
362036-363036	270 x 360 mm	6+6	6+6	6+6	6+6	4+4	4+4	4+4	4+4
362056-363056	330 x 560 mm	10+10	10+10	10+10	9+9	8+8	8+8	8+8	7+7
362073-363073	360 x 730 mm	14+14	14+14	13+13	13+13	12+12	12+12	11+11	11+11

配套									
5020 型	截止阀								
632 型	5995 型								
编号	尺寸	3/4"	1"	3/4"	1"	3/4"	1"	3/4"	1"
362056-363056	330 x 560 mm	7+7	7+7	7+7	5+5	6+6	5+5	6+6	5+5
362073-363073	360 x 730 mm	11+11	10+10	10+10	10+10	10+10	8+8	9+9	8+8

配套									
5020	截止阀								
633 型	648018 型								
635 型	5995 型								
编号	尺寸	3/4"	1"	3/4"	1"	3/4"	1"	3/4"	1"
362073-363073	360 x 730 mm	11+11	10+10	10+10	10+10	10+10	8+8	9+9	8+8

配套									
5020 型	截止阀								
6470 型	5995 型								
编号	尺寸	3/4"	1"	3/4"	1"	3/4"	1"	3/4"	1"
362056-363056	330 x 560 mm	8+8	7+7	7+7	6+6	7+7	6+6	6+6	5+5
362073-363073	360 x 730 mm	11+11	10+10	10+10	10+10	10+10	8+8	10+10	9+9

350型和592型分水器与配套箱体的选择

配套									
5020型	截止阀								
6480型	648018型								
6490型	5995型								
编号	尺寸	3/4"	1"	3/4"	1"	3/4"	1"	3/4"	1"
362073-363073	360 x 730 mm	11+11	10+10	10+10	10+10	10+10	8+8	10+10	9+9

配套									
5020型	截止阀								
676型	5995型								
编号	尺寸	3/4"	1"	3/4"	1"	3/4"	1"	3/4"	1"
362056-363056	330 x 560 mm	8+8	8+8	8+8	8+8	7+7	7+7	7+7	6+6
362073-363073	360 x 730 mm	11+11	11+11	11+11	11+11	11+11	10+10	10+10	10+10

配套									
5020型	截止阀								
677型	648018型								
	5995型								
编号	尺寸	3/4"	1"	3/4"	1"	3/4"	1"	3/4"	1"
362073-363073	360 x 730 mm	11+11	11+11	11+11	11+11	11+11	10+10	10+10	10+10

用途

箱体安装首先需要确认使用哪一类分水器及其相应配置。

一体式集分水器支架

将一体式集分水器固定在箱体内需要使用362001型支架。

固定架安装在分水箱底部的凸槽上。固定架上下的安装距离需要考虑到给区域阀留出足够的空间。

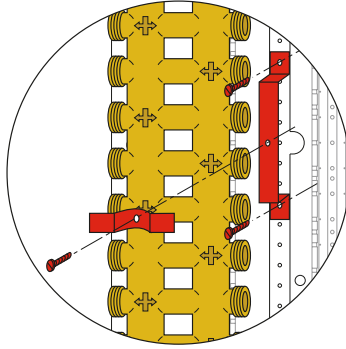

362001型支架安装图示

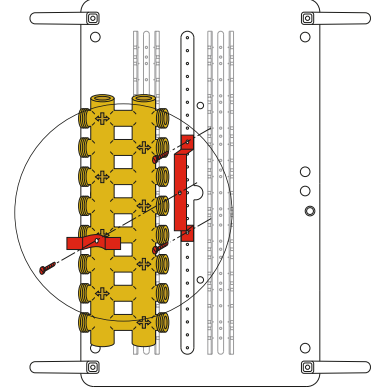

356型集分水器在箱体内的安装示例

简易型

配套678型区域阀

配套633型区域阀

配套6480型区域阀

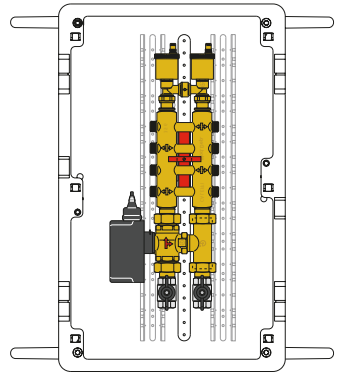
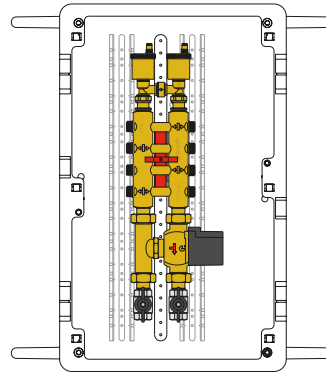
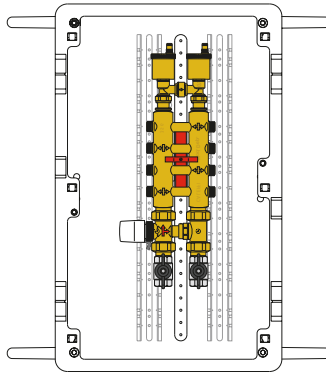
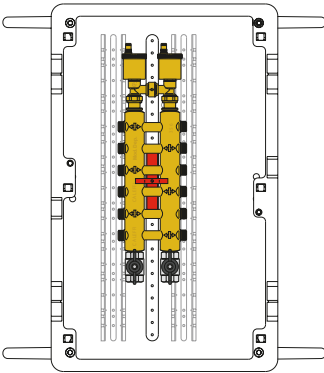

分体式集分水器支架

350, 351, 592和598型分体式分水器 (3/4" 和 1") 固定在箱体内需要使用360001型支架。349型分体式分水器使用360002型支架。确保支架安装的前后距离给供水管及区域阀一端留出足够的空间。右图所示红点处相对应的固定孔适合支管间距50mm的分水器, 未标示红点的适合支管间距35mm的分水器。

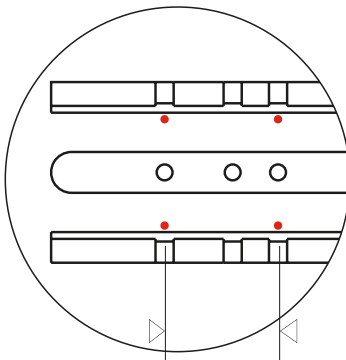
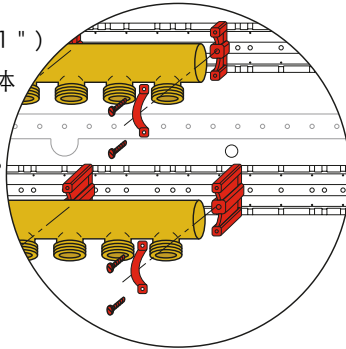

360001型支架安装图示

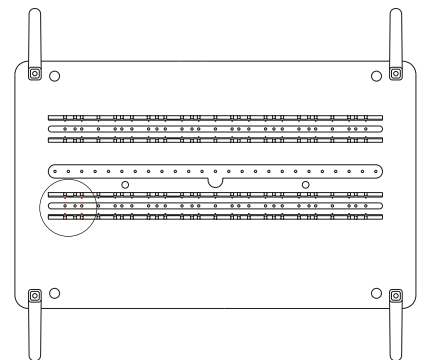
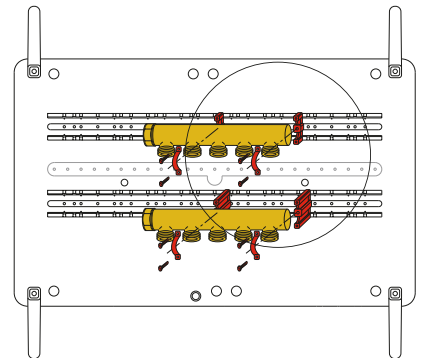

安装方式

箱体底部与框架之间的支撑距离可选择80mm和100mm两种。

包装内支撑钉长度为100mm（图1），将其上部分沿痕迹处折断（图2），长度即变为80mm（图3）。分水箱与墙壁固定的塑料支撑片可以固定在分水箱底部上（图4）或者分水框上（图5），支撑片可水平或垂直固定。其卡槽的设计防止了抹灰时支撑片转动。

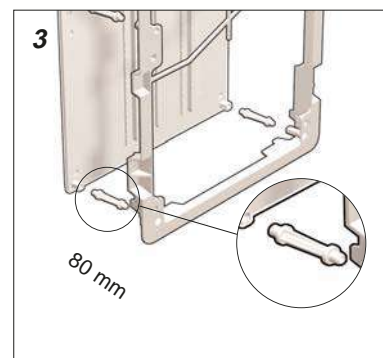
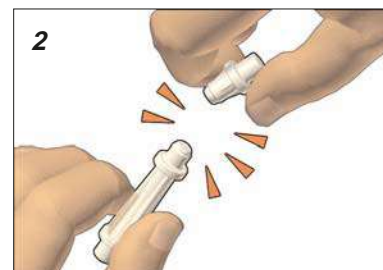
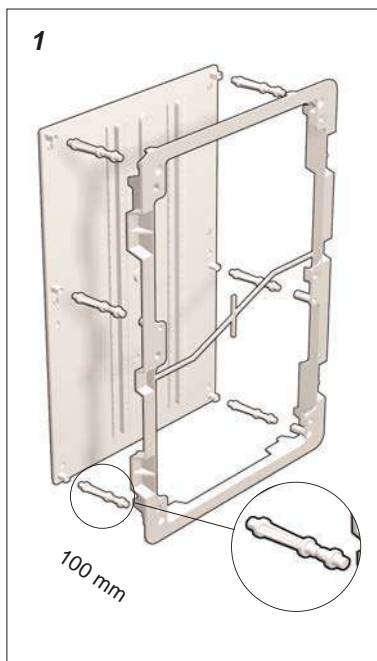
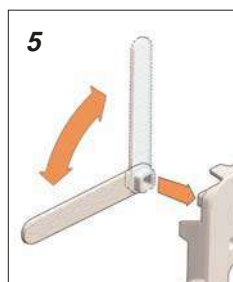
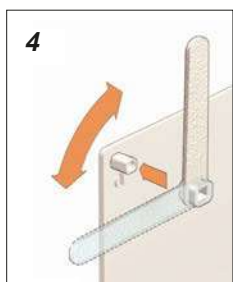

分水箱包装内提供了边框保护条，用于没有经过管道的两侧。这样可以防止在墙壁抹灰时杂质掉入箱体。保护条有水平和垂直方向两种，根据实地安装情况使用。

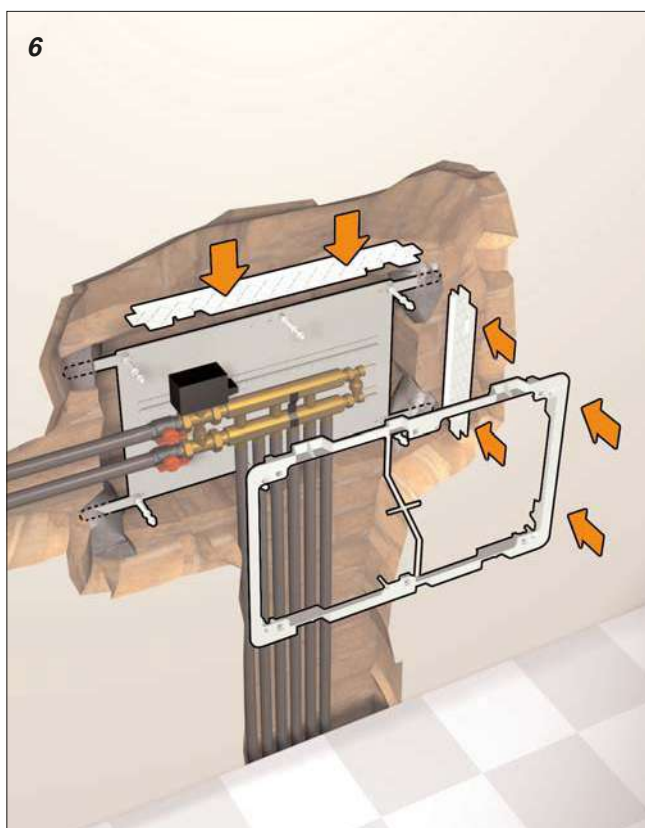

保护条与箱体背板有相应的卡槽，因此建议在固定底板前将保护条卡上。

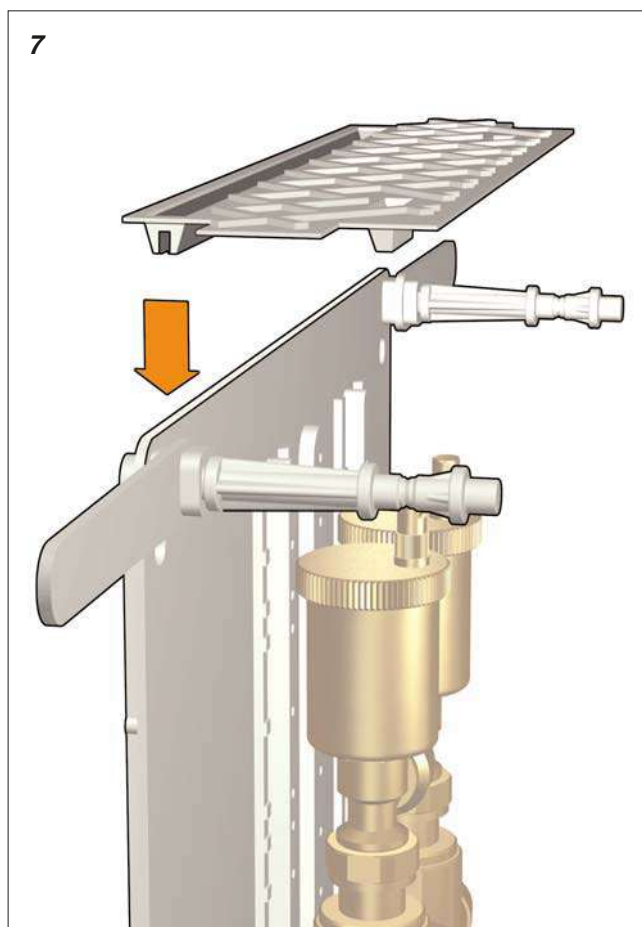

分水箱内部元件安装试压完毕后，在进行墙体处理前，需要将相应的箱门保护膜（随包装附带）贴上防止水泥进入箱体。

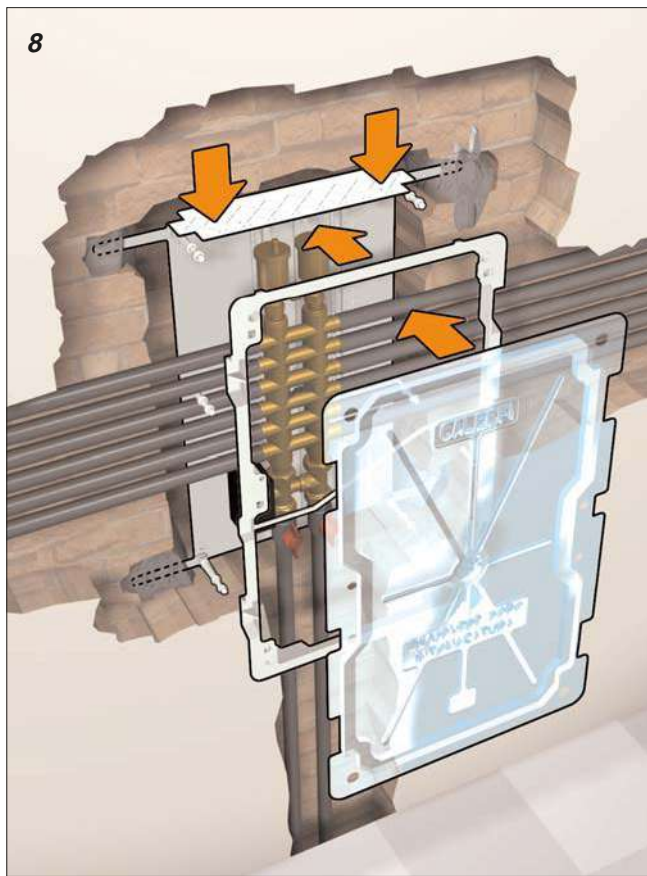

分水箱同样可以在分水器连接试压完毕后再根据前后距离安装，这对于很多在非承重墙上事先掏空的安装情况很适合。

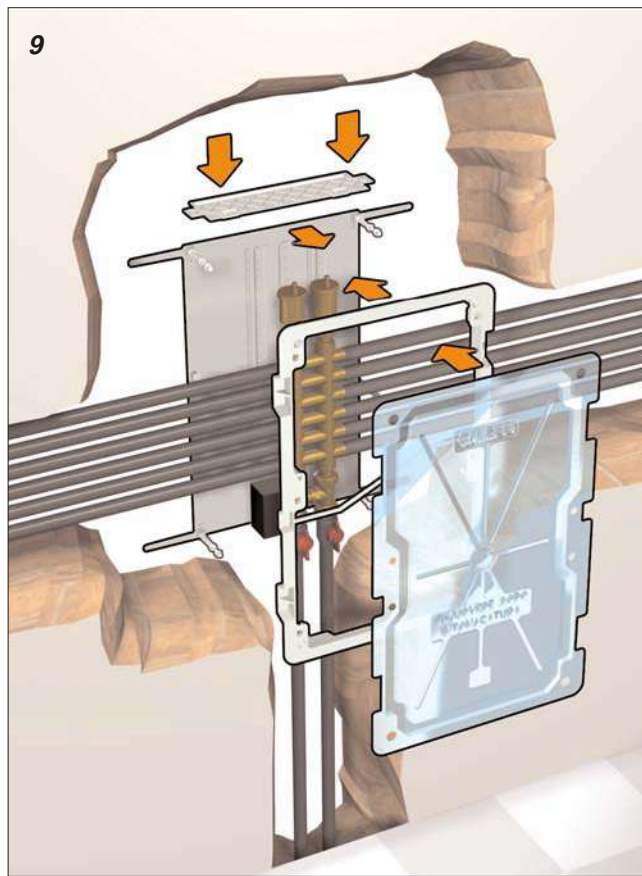

分水像边框的形状及其固定卡齿（图10和10a）保证了箱框与水泥完好地粘在一起，避免墙面粉刷时裂痕出现。

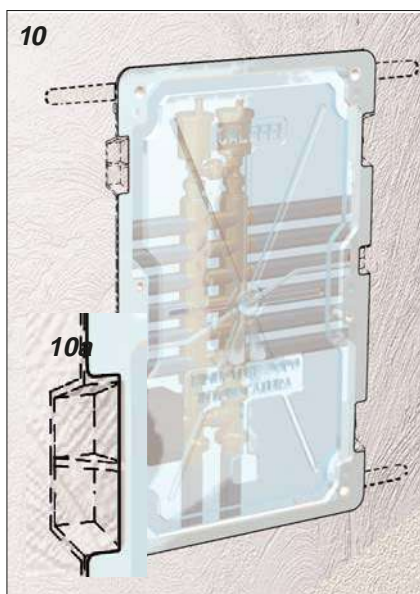

箱体底板背面（图11）为网状结构，易于灰浆粘附在上面。。

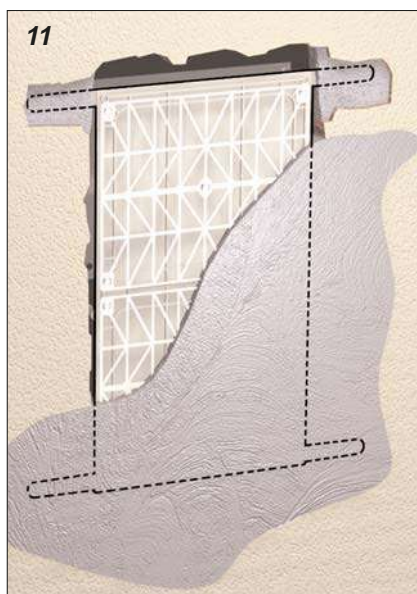

箱框上有一个防挤压条，在水泥粉刷完毕后取掉。

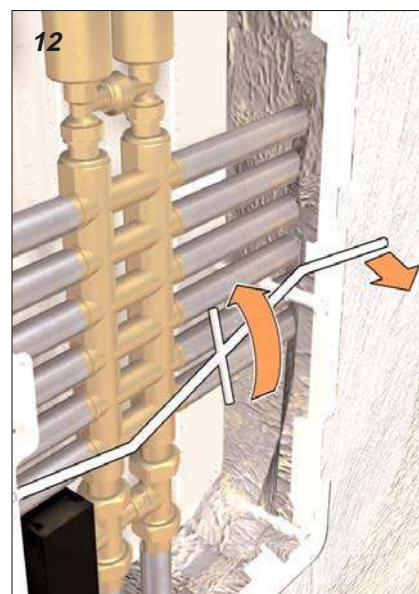

分水箱盖板与箱框的4个固定螺钉设计易于操作，可以使用5mm的六角扳手或者硬币即可开关（图13，13a）。螺钉转动造成下部的螺母变形因此起到固定的作用。

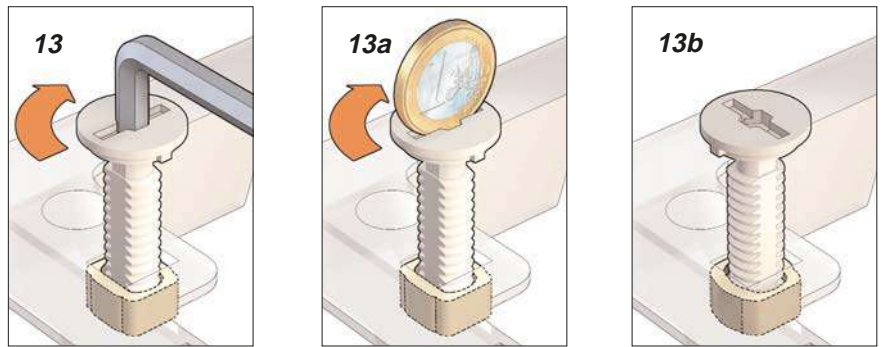

箱体盖板有30mm的可调节余量，可以遮盖粉刷墙面时尺寸的出入。

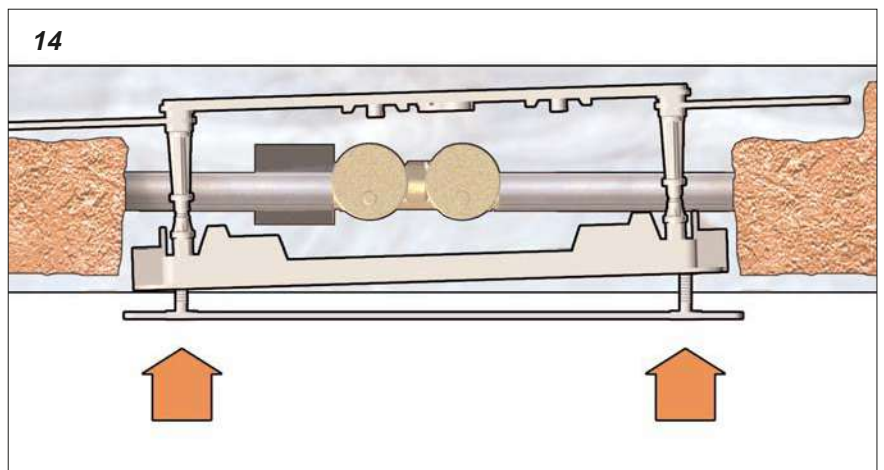

箱体盖上的通风口设计保证了热风水平送出且风速减低，防止热空气沿盖板上升在墙壁上留下空气污渍。

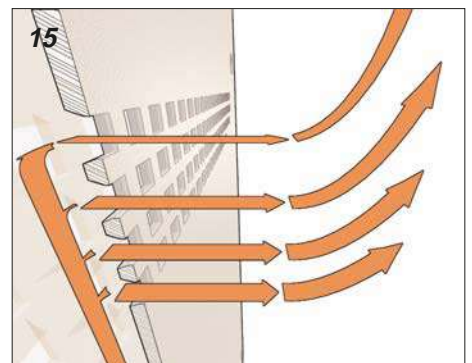

363型分水框架的安装

另外一个典型安装方式是在墙体预留空间上安装（图16），因此只需要使用363型分水框架。框架则直接如图5所示固定在墙面。

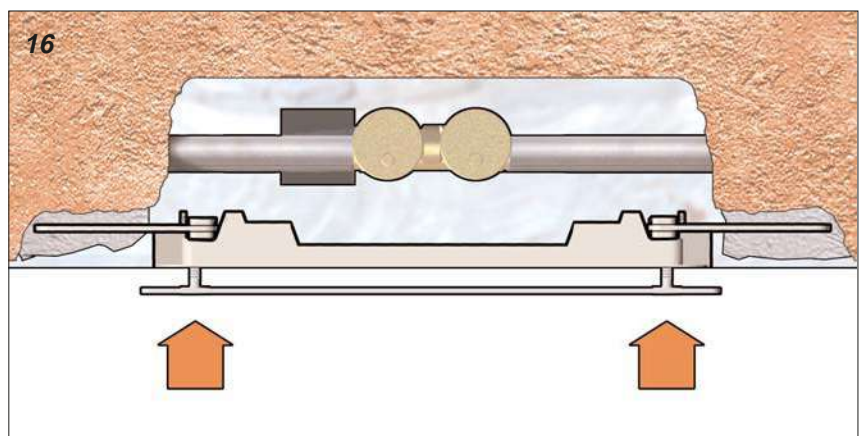

362073箱体垂直安装与362036箱体水平安装时宽度一致，所以可以如右图所示安装，便于多套分水器组合时使用。

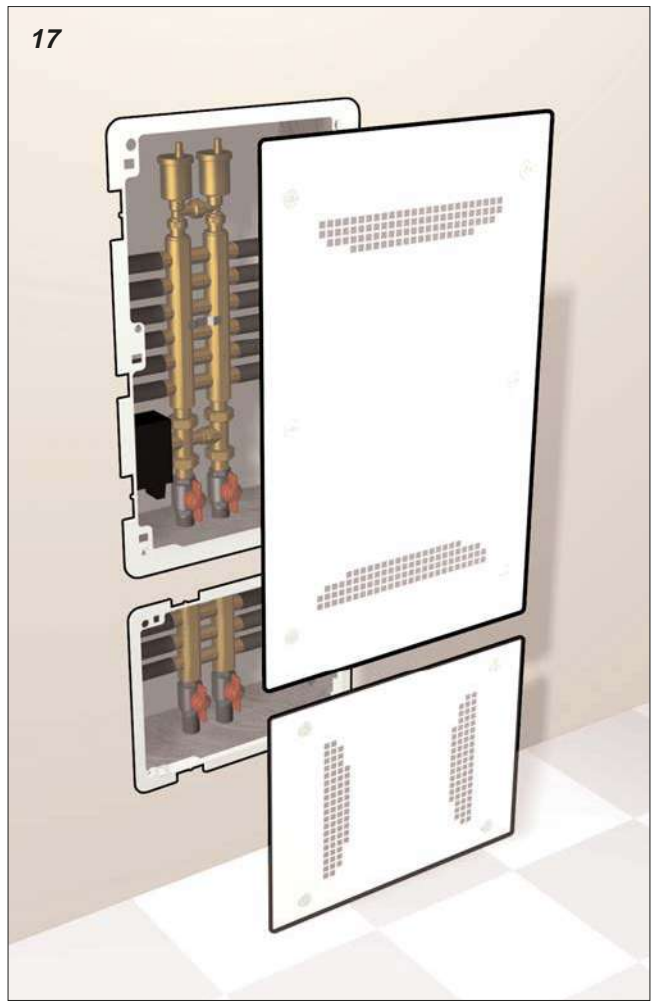

362073+362036分水箱在系统上的运用图示

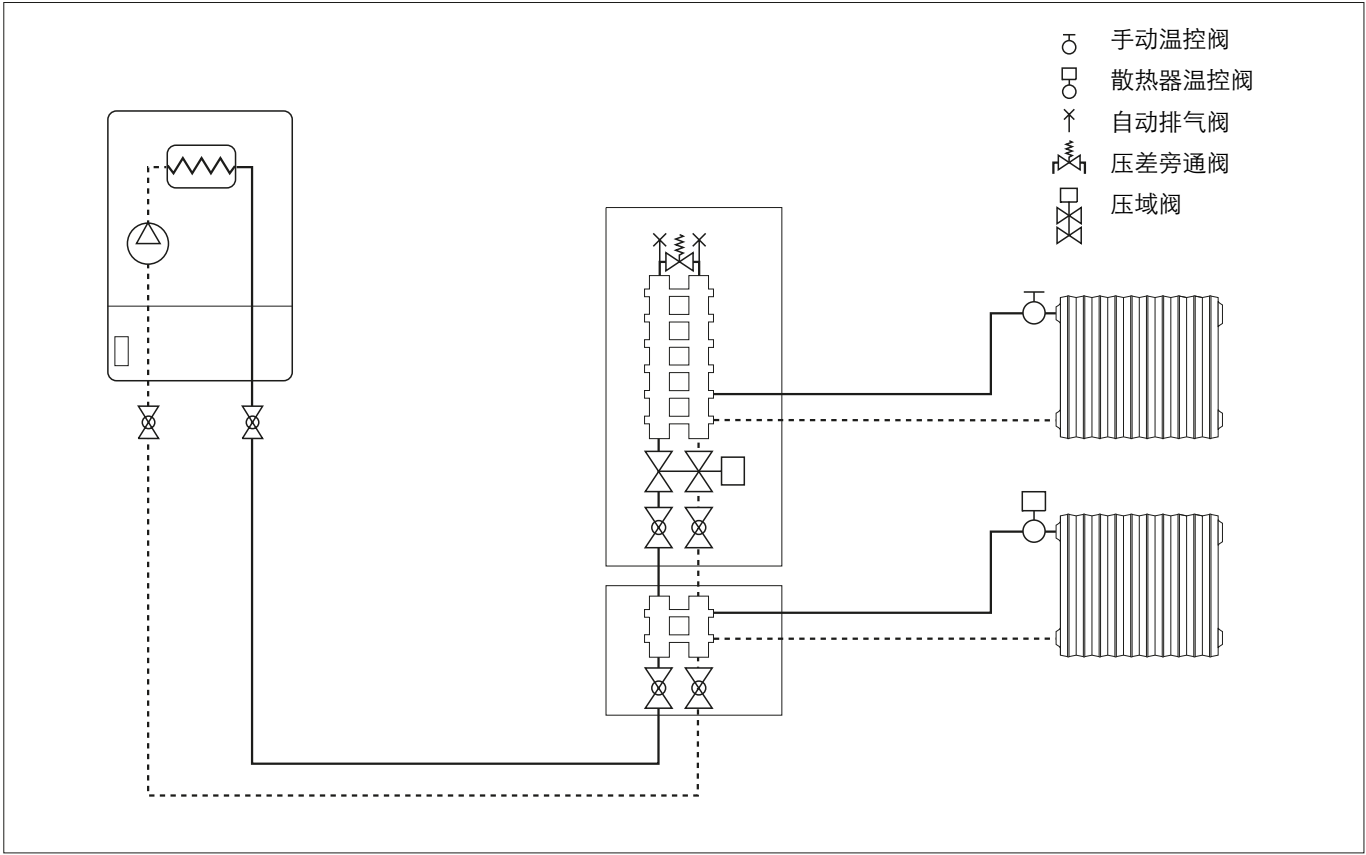

性能概述

362型

塑料分水箱

RAL9010白色, 尺寸 (h×b×p)

362036型 mm 360×270×100/80

362056型 mm560×330×100/80

363型

塑料分水框

RAL9010白色, 尺寸 (h×b×p)

363036型 mm360×270×100/80

363056型 mm560×330×100/80

360001型

分水器固定支架。适合于350和592分水器3/4 " -1 " 型号。包装内为2个长支架和2个短支架。

360002型

分水器固定支架。适合于349分水器3/4 " 型号。包装内为2个长支架和2个短支架。

362001型

分水器固定架。适合于356、357及640型集分水器。



我们保留对本产品样本内产品及技术数据随时更改的权力, 恕不另行通知。

意大利卡莱菲公司北京办事处

地址:北京市大兴区长子营镇长恒路20号院联东U谷14号楼 102615 电话:(010)-5637 0265

全国统一服务热线: 400 089 0178

www.caleffi.cn info@caleffi.com.cn © Copyright 2016 Caleffi