

Pre-assembled distribution manifolds for heating and air-conditioning systems



663 series



01065/18 GB

replaces dp 01065/06 GB

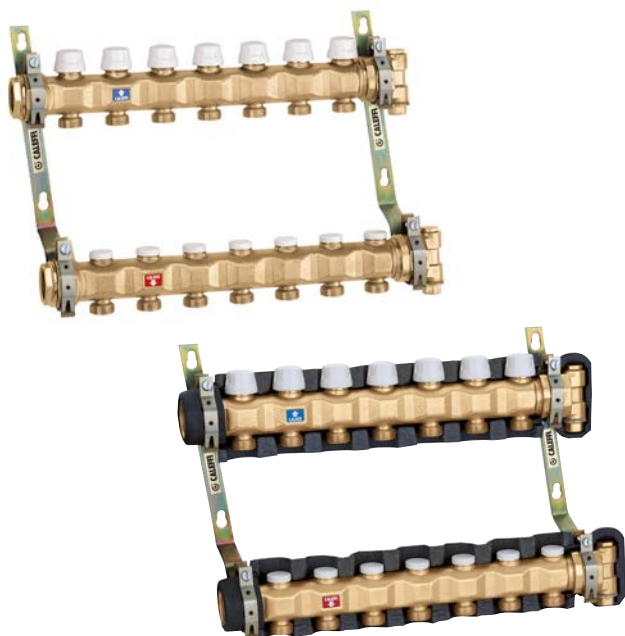

Function

The pre-assembled distribution manifolds are designed to optimise distribution of the medium in heating and air-conditioning system circuits.

They ensure accurate flow control to the single circuits, with shut-off valves and reduced depth to facilitate connecting the outlet pipes during installation.

There is also a version that comes complete with hot pre-formed insulation to limit thermal dispersion and, above all, to prevent condensation on the surface when used in air-conditioning systems.

Reference documentation

- Tech. brochure 01042 6561 series thermo-electric actuator
- Tech. brochure 01142 6563 series thermo-electric actuator with manual opening and position indicator
- Tech. brochure 01041 Automatic flow regulators
- Tech. brochure 01054 5020 series automatic air vents

Product range

663 series	Pre-assembled distribution manifold	size 1 1/4"
663 IS series	Pre-assembled distribution manifold for air-conditioning systems	size 1 1/4"

Technical specifications

Materials

Flow manifold

Body: brass EN 1982 CB753S

Lockshield valve

Headwork: brass EN 12164 CW614N

Lockshield stem: brass EN 12164 CW614N

Seals: EPDM

Cap: self-extinguishing polycarbonate

Adjustment key: 5 mm Allen key

Return manifold

Body: brass EN 1982 CB753S

Shut-off valve

Headwork: brass EN 12164 CW614N and PA

Lockshield stem: stainless steel

Obturator: EPDM

Springs: stainless steel

Seals: EPDM

Knob: ABS

End fitting

Body: brass EN 12165 CW617N

Performance

Medium: water, glycol solutions

Max. percentage of glycol: 30%

Maximum working pressure: 10 bar

Working temperature range: 5–100°C

Main connections: 1 1/4" F; 1" F with reduction as standard

Centre distance: 195 mm

Outlets: 3/4" M - Ø 18

Centre distance: 50 mm

Technical specifications of insulation

Material: closed cell expanded PE-X

Thickness: 20 mm

Density: - inner part: 30 kg/m³

- outer part: 50 kg/m³

Thermal conductivity (DIN 52612): - at 0°C 0,038 W/(m·K)

- at 40°C 0,045 W/(m·K)

Coefficient of resistance to water vapour diffusion (DIN 52615): > 1300

Working temperature range: 0–100°C

Reaction to fire (DIN 4102): class B2

Dimensions

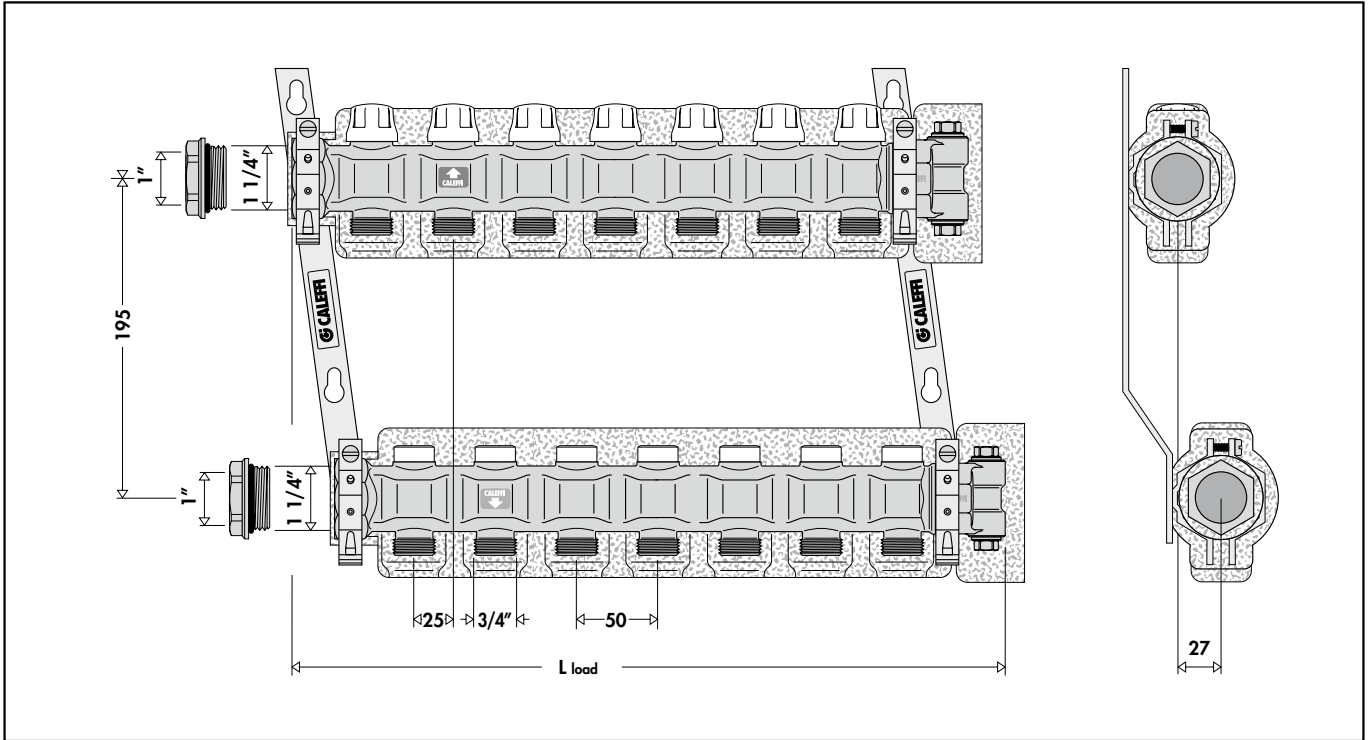

Code without insul.	6637C5	6637D5	6637E5	6637F5	6637G5	6637H5	6637I5	6637L5	6637M5	6637N5	6637O5
Code with insul.	6637C5 IS	6637D5 IS	6637E5 IS	6637F5 IS	6637G5 IS	6637H5 IS	6637I5 IS	6637L5 IS	6637M5 IS	6637N5 IS	6637O5 IS
No. of outlets	3	4	5	6	7	8	9	10	11	12	13
Total L	220	270	320	370	420	470	550	600	650	700	750
Weight (kg)	4,8	5,4	5,9	6,8	7,4	8,1	8,5	9,6	10,5	11	11,6

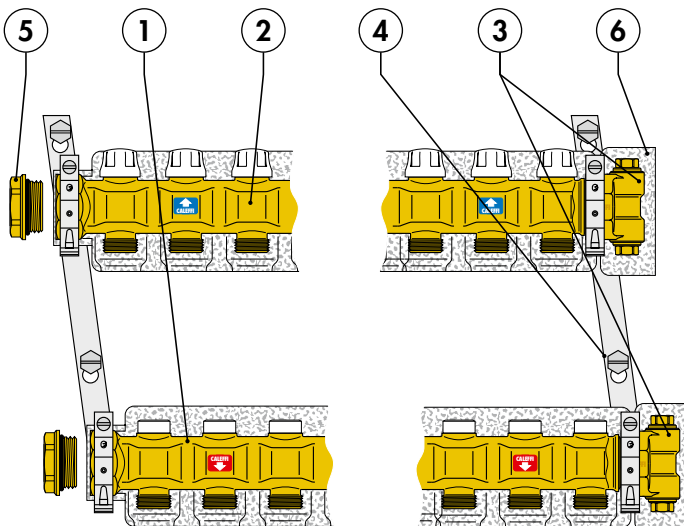

Characteristic components

- 1 Flow manifold complete with lockshield valves for flow rate pre-adjustment
- 2 Return manifold complete with shut-off valves to accommodate thermo-electric actuators
- 3 End fittings composed of double radial end fitting and plugs
- 4 Pair of brackets for box mounting
- 5 1 1/4" M x 1" F reduction
- 6 Hot pre-formed shell insulation (version with insulation)

Construction details

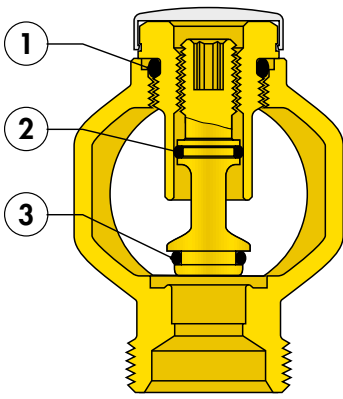

Flow manifold

The flow manifold is equipped with outlet circuit shut-off and lockshield valves.

To prevent leaks or seepage over time, perfect sealing is guaranteed by EPDM O-Rings on the headwork (1) and the lockshield actuator stem (2), while an O-ring on the obturator (3) makes it possible to shut off the outlet circuit completely when required.

Return manifold

The return manifold is equipped with manual shut-off valves (1), in order to cut off the flow rate to each individual circuit.

They can also be fitted with a thermo-electric actuator (2) that, when used with a room thermostat, maintains the ambient temperature at the set values regardless of thermal load variations.

The obturator stem (3) consists of a single piece of ground stainless steel, in order to minimise friction and prevent building up of dangerous limescale deposits.

The headwork has a double seal (4) – (5) EPDM O-ring on the slide stem.

The EPDM obturator (6) is shaped to optimise the hydraulic characteristics of the valve and minimise noise caused by the flow of the medium, even during gradual opening or closing when operating with a thermo-electric actuator.

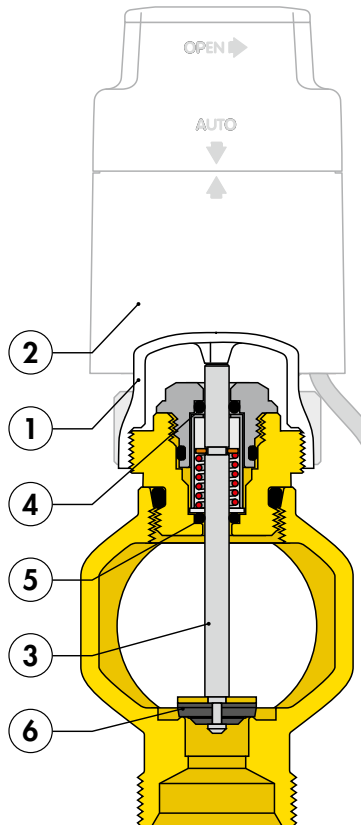

External shape of the manifolds and brackets

A special mention should be given to the outer shape of the manifold that, thanks to the casting process, can be shaped as needed.

In this case, recesses have been made where the pipe descending from the upper manifold passes, allowing it to be partially housed to reduce the depth. This does not alter the pressure drops, since the cross-sections of the recessed parts (a) are the same as those in the zones where the outlets (b)+(c) branch, and where the adjusters (lockshield and shut-off valves) obstruct the flow of the medium.

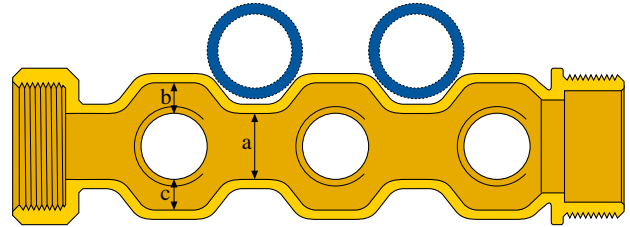

The partial pipe housing in the manifold outline is also helped by the fastening brackets, which are made with an angle that provides a 25 mm offset between the upper and lower manifolds.

As shown in the figure, this misalignment, at the time of installation, makes a perfect match automatic between the position of the pipe and manifold outline.

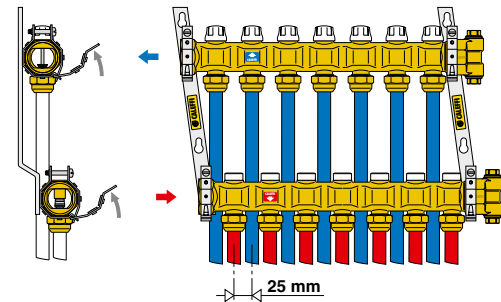

Pre-formed insulation

The 663 series manifold is also offered in a version complete with hot pre-formed insulation. This solution is recommended for applications in which it is necessary to limit thermal losses (installations outdoors or in particularly cold places) or, specifically, to prevent condensation on its surface when used in air-conditioning systems.

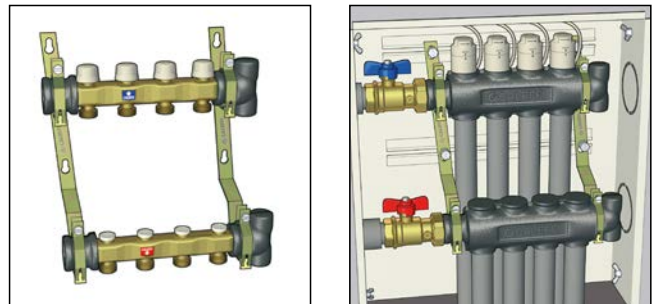

The insulation has been specially designed to facilitate coupling with the manifold and any accessories such as thermo-electric actuators, as well as installation in boxes.

Hydraulic characteristics

To determine the hydraulic characteristics of the circuit, it is necessary to calculate the total pressure drop in the medium as it flows through the devices that compose the manifold assembly and fan-coil circuits.

From a hydraulic point of view, the system consisting of the manifold assembly and the circuits can be represented as a set of hydraulic elements arranged in series and in parallel.

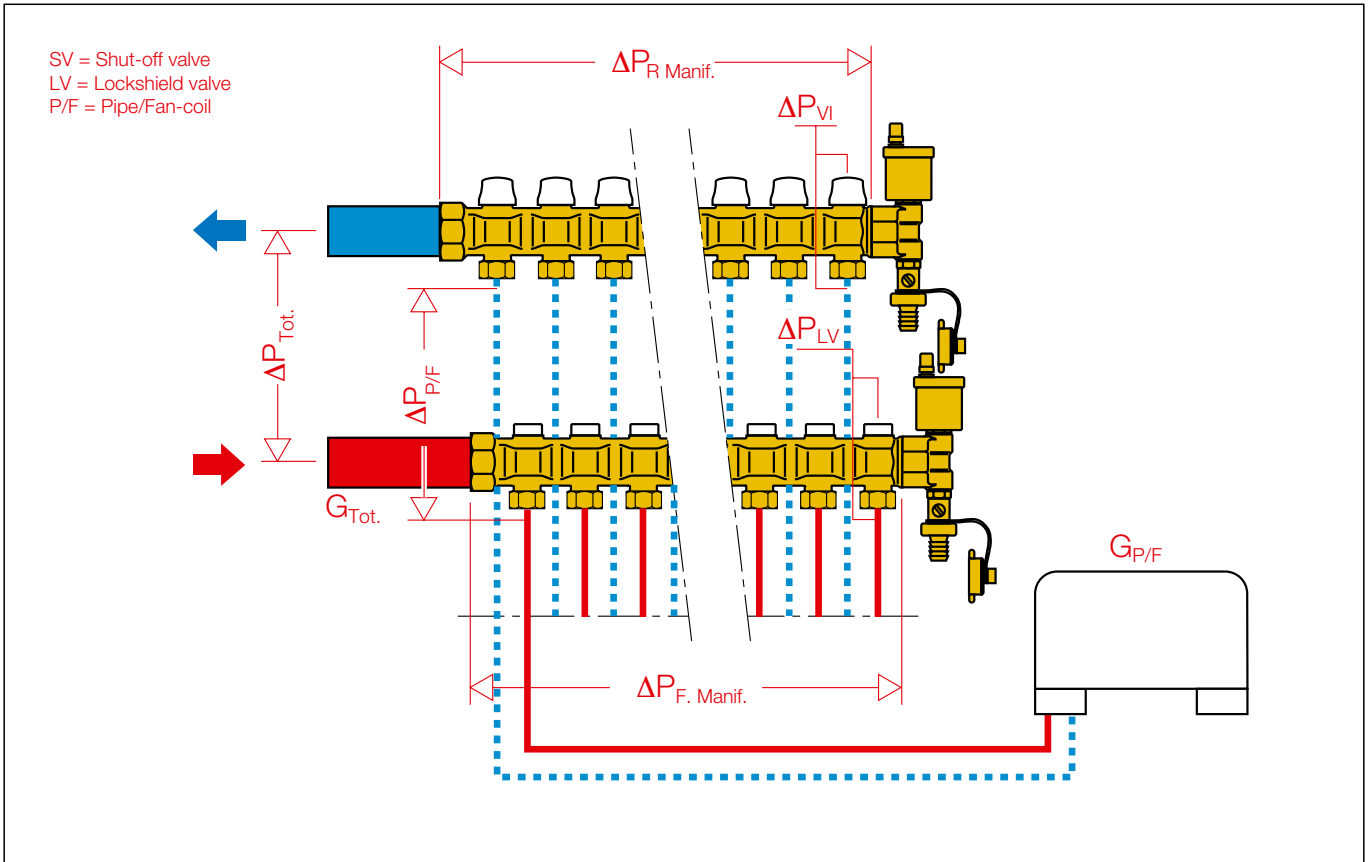

ΔP_{Tot} = Total loss at the ends of the manifold
(Flow + Return + Pipe/Fan-coil)

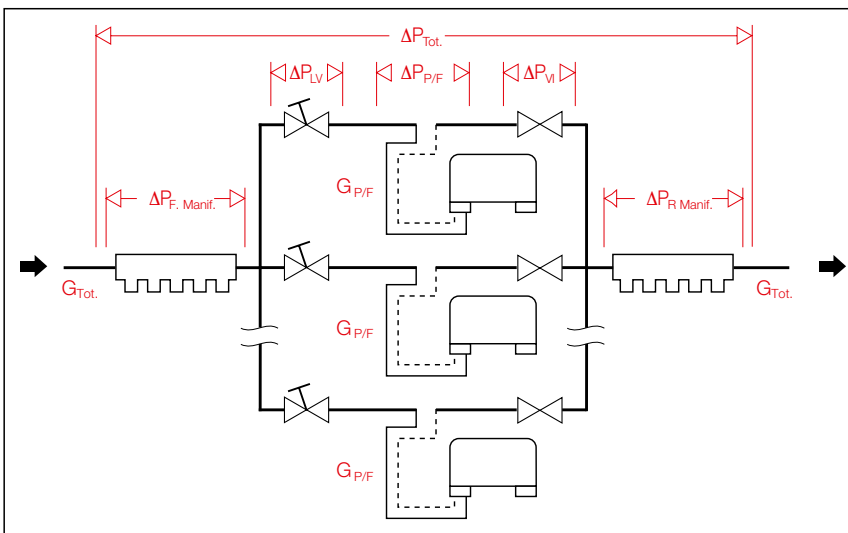

- ΔP_{LV} = Localised loss in the lockshield valve circuit (P/F circuit flow rate)
- $\Delta P_{P/F}$ = Pipe/Fan-coil loss (P/F circuit flow rate)
- ΔP_{SV} = Localised loss in the P/F circuit shut-off valve (P/F circuit flow rate)
- $\Delta P_{Manif. M}$ = Distributed loss in the flow manifold (total flow rate)
- $\Delta P_{Manif. R}$ = Distributed loss in the return manifold (total flow rate)

$$\Delta P_{Tot.} = \Delta P_{LV} + \Delta P_{P/F} + \Delta P_{SV} + \Delta P_{Manif. M} + \Delta P_{Manif. R}$$

(1.1)

When the hydraulic characteristics of each component and the design flow rates are known, the total loss can be calculated as the sum of the partial pressure drops for each specific component in the system, as given by the formula (1.1).

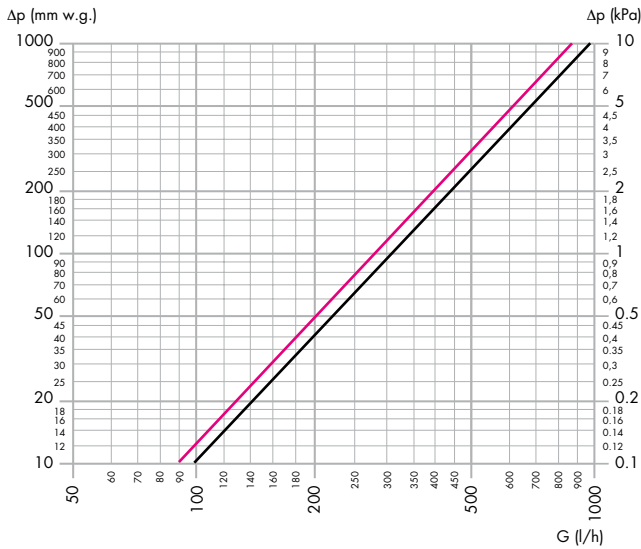

	Kv	Kv _{0.01}
Lockshield valve fully open	3.10	310
Shut-off valve	2.87	287

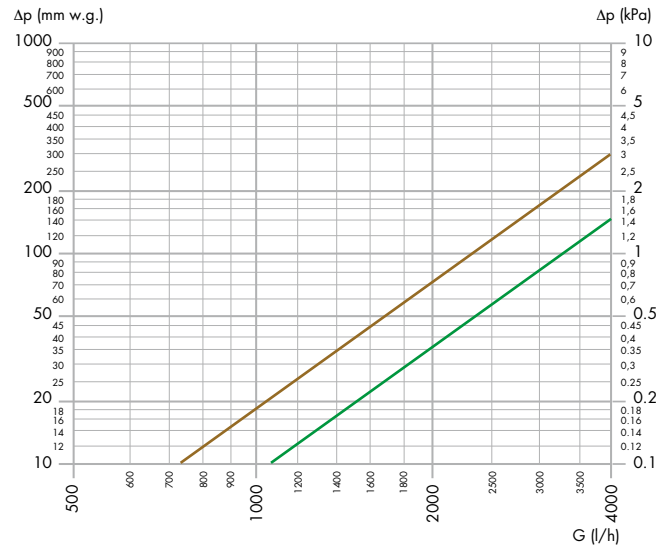

	Kv	Kv _{0.01}
Flow/return manifold, 3x7 ports	33.5*	3350*
Flow/return manifold, 8x13 ports	23.5*	2350*

* Average value

- Kv = flow rate in m³/h for a pressure drop of 1 bar

- Kv_{0.01} = flow rate in l/h for a pressure drop of 1 kPa

Example of total head loss calculation

Supposing we need to calculate the head loss of a manifold with three circuits with the following characteristics:

Total manifold flow rate: 900 l/h

The pipes and fan heaters of the three circuits have the following flow rate and pressure drop characteristics:

Circuit 3	Circuit 1	Circuit 2	
G ₁ = 200 l/h	G ₂ = 300 l/h	G ₃ = 400 l/h	
ΔP _{Fan 1} = 1.3 kPa	ΔP _{Fan 2} = 3 kPa	ΔP _{Fan 3} = 5.3 kPa	(1.2)
ΔP _{Pipe 1} = 1.7 kPa	ΔP _{Pipe 2} = 7.8 kPa	ΔP _{Pipe 3} = 7.2 kPa	
ΔP _{P/F1} = 1.7 + 1.3 = 3 kPa	ΔP _{P/F2} = 7.8 + 3 = 10.8 kPa	ΔP _{P/F3} = 7.2 + 5.3 = 12.5 kPa	

Each term in the formula (1.1) is calculated using the following relationship:

$$\Delta P = G^2 / Kv_{0.01}^2$$

- G = flow rate in l/h
- ΔP = pressure drop in kPa (1 kPa = 100 mm w.g.)
- Kv_{0.01} = flow rate in l/h through the device that corresponds to a pressure drop of 1 kPa

It should be stressed that ΔP_{Tot.} must be calculated considering the circuit with the greatest pressure drops distributed throughout the whole pipe + fan-coil circuit.

In the case we are examining, the relevant circuit is No. 3.

It follows that:

$$\left. \begin{aligned} \Delta P_{LV3} &= 400^2 / 310^2 = 1.7 \text{ kPa} \\ \Delta P_{P/F3} &= 12.5 \text{ kPa} \\ \Delta P_{V13} &= 400^2 / 287^2 = 1.9 \text{ kPa} \\ \Delta P_{Manif. M} &= 900^2 / 3350^2 = 0.07 \text{ kPa} \\ \Delta P_{Manif. R} &= 900^2 / 3350^2 = 0.07 \text{ kPa} \end{aligned} \right\} \text{Values obtained by neglecting the changes due to tapping off flow rate to the single branched circuits.}$$

Using formula (1.1) and adding up all the calculated terms, we obtain:

$$\Delta P_{Tot.} = 1.7 + 12.5 + 1.9 + \cancel{0.07} + \cancel{0.07} \approx 16 \text{ kPa}$$

Note:

Because of the low head losses for the manifolds, the two terms relating to them can be neglected.

Generally, the total pressure drop is reasonably close to that of the circuit composed of the pipes, fan-coil and fully open lockshield valve.

Using the lockshield valve

The lockshield valve makes it possible to balance the single fan-coil circuits to obtain the effective flow rates determined at the design stage for each of them. If we consider each single circuit to be composed of: lockshield valve, pipe/fan-coil and shut-off valve. To be able to set the system correctly it is necessary to take account of the following data:

- the flow rate of the medium that must pass through each circuit (design data).
- the head loss which, for this flow rate, is generated in each circuit:

$$\Delta P_{\text{Circuit}} = \Delta P_{P/F} + \Delta P_{SV} \quad (1.3)$$

- the head loss of the most disadvantaged circuit:

$$P_{\text{Circuit} + \text{disadvantaged}} = \Delta P_{LV} + \Delta P_{P/F} + \Delta P_{SV} \quad (1.4)$$

In all of the circuits, for a flow rate of G_{Circuit} , the lockshield valve must provide an additional pressure drop equal to the difference, which we can indicate as ΔP_{LV} (**ΔP lockshield**).

To permit an increase in flow rate, we sometimes consider the lockshield of the circuit with the greatest head losses open to 80%.

Once the values of ΔP_{LV} and G_{Circuit} have been established for each circuit, we need to refer to the graph displaying the hydraulic characteristics of the lockshield valve to choose the optimum adjustment curve to which the valve adjustment position corresponds.

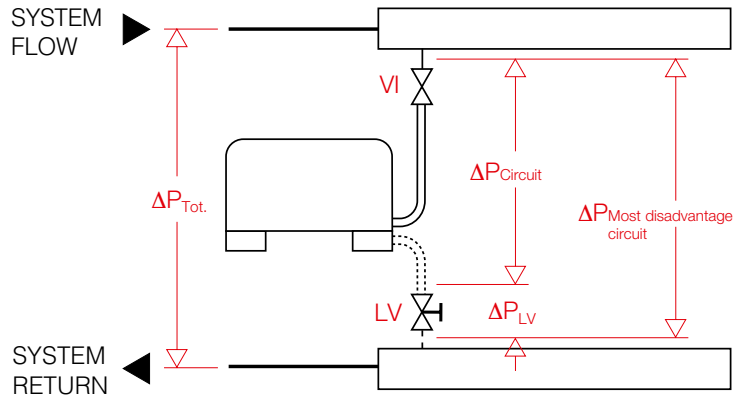

Example of pre-adjustment

Let us suppose that we need to balance three circuits with the characteristics of loss of head and flow rate for the pipe/fan heater assembly shown in the example (1.2).

Since circuit No. 3 is the least favourable one, because it has the greatest pressure drop for the pipe/fan-coil assembly, we need to adjust the remaining circuits:

Circuit 2
 $\Delta P_{P/F3} = 12.5 \text{ kPa}$
 $G_3 = 400 \text{ l/h}$

$\Delta P_{LV3} = 400^2/310^2 = 1.7 \text{ kPa}$
 $\Delta P_{SV3} = 400^2/287^2 = 1.9 \text{ kPa}$

With formula (1.4):
 $\Delta P_{\text{Circuit } 3} = 1.7 + 12.5 + 1.9 = 16.1 \text{ kPa}$
+ disadvantaged

Circuit 3
 $\Delta P_{P/F1} = 3 \text{ kPa}$
 $G_1 = 200 \text{ l/h}$

$\Delta P_{SV1} = 200^2/287^2 = 0.5 \text{ kPa}$

with formula (1.3):
 $\Delta P_{\text{Circuit } 1} = 3.0 + 0.5 = 3.5 \text{ kPa}$

Circuit 1
 $\Delta P_{P/F2} = 10.8 \text{ kPa}$
 $G_2 = 300 \text{ l/h}$

$\Delta P_{SV2} = 300^2/287^2 = 1.1 \text{ kPa}$

with formula (1.3):
 $\Delta P_{\text{Circuit } 2} = 10.8 + 1.1 = 11.9 \text{ kPa}$

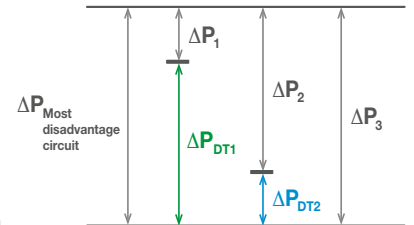

$$\Delta P_{\text{Circuit} + \text{disadvantaged}} \cong 16 \text{ kPa}$$

To balance circuits 1 and 2, the data we need for each circuit for reading the pre-setting position will be as follows:

Circuit 1
 $\Delta P_{LV1} = 16 - 3.5 = 12.5 \text{ kPa}$
 $G_1 = 200 \text{ l/h}$
 No. of adjustment turns = 2

Circuit 2
 $\Delta P_{LV2} = 16 - 11.9 = 4.1 \text{ kPa}$
 $G_2 = 300 \text{ l/h}$
 No. of adjustment turns = 3

Circuit 3
 Adjustment position fully open

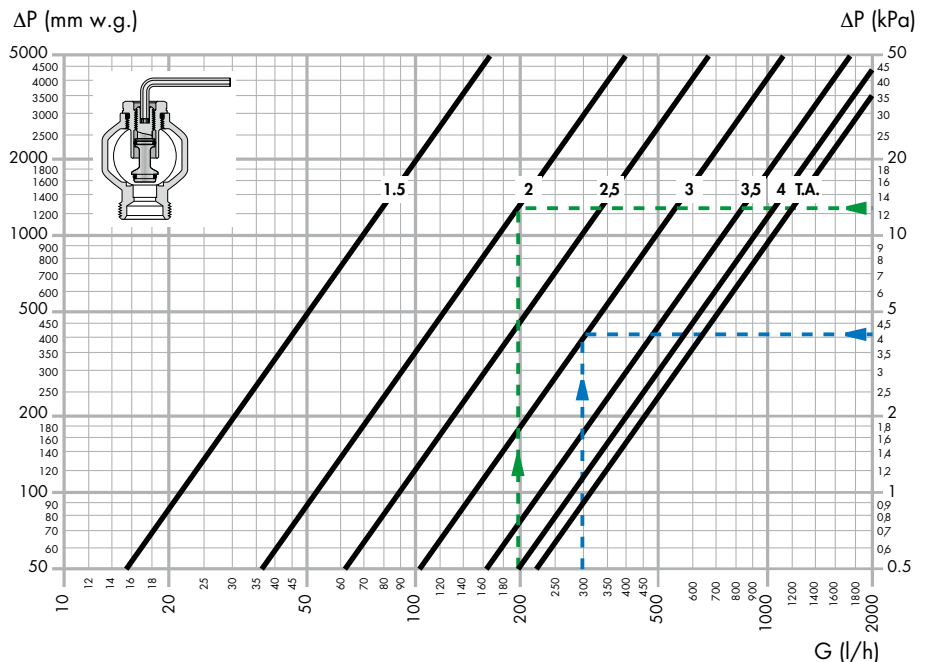

Lockshield hydraulic characteristics

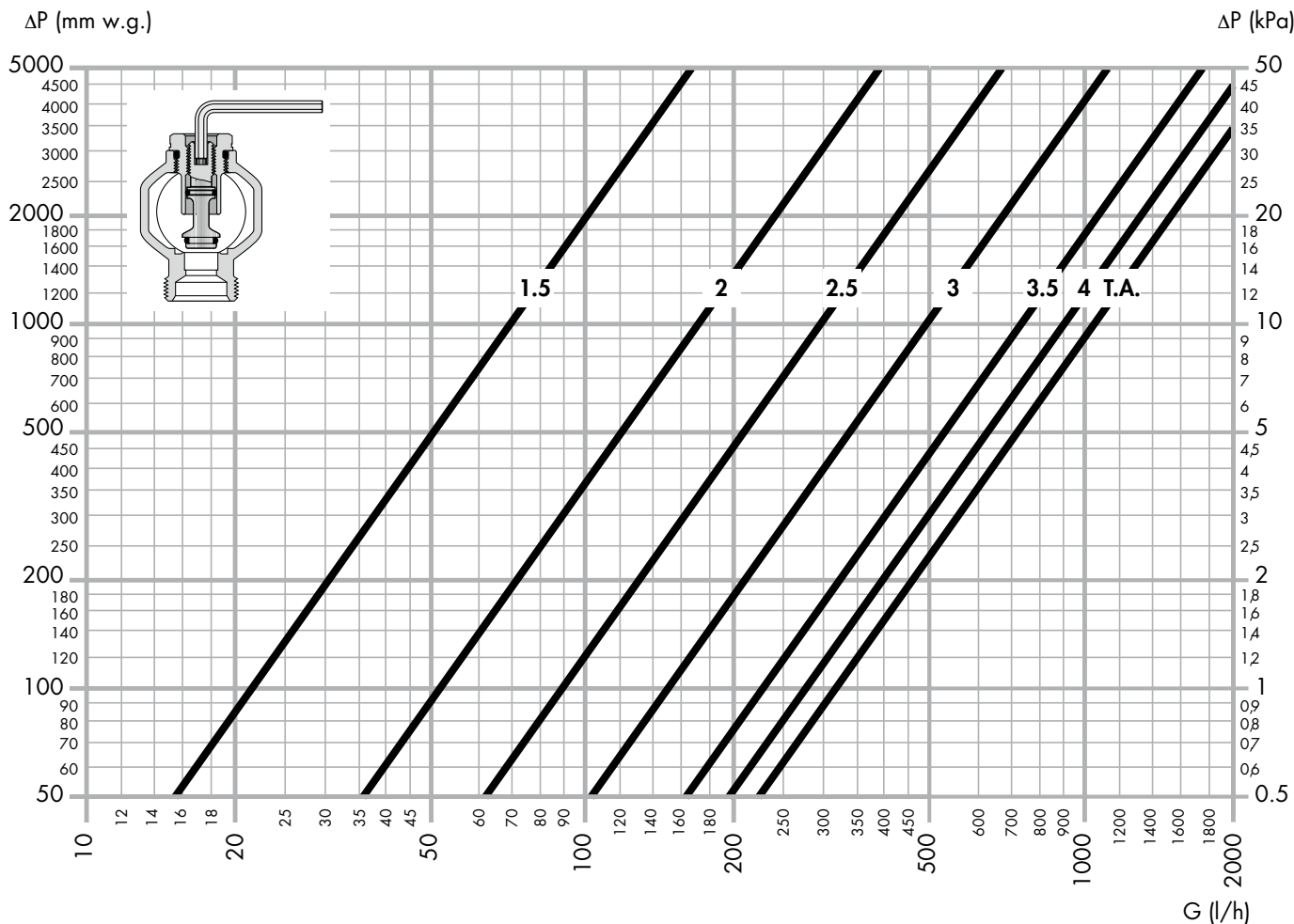

Adjustment position	1.5	2	2.5	3	3.5	4	F.O.
Kv	0.22	0.53	0.90	1.50	2.30	2.90	3.10
Kv_{0.01}	22	53	90	150	230	290	310

- Kv = flow rate in m³/h for a pressure drop of 1 bar

- Kv_{0.01} = flow rate in l/h for a pressure drop of 1 kPa

SPECIFICATION SUMMARY

663 series

Pre-assembled distribution manifold for heating systems with 3 (from 3 to 13) outlets. Brass body. EPDM seals. Main connections 1 1/4" (1" with reduction as standard), F thread, centre distance 195 mm. Outlet connections 3/4" M - Ø 18, centre distance 50 mm. Medium water and glycol solutions. Max. percentage of glycol 30%. Maximum working pressure 10 bar. Working temperature range 5–100°C. Composed of:

- Flow manifold complete with lockshield valves that have 5 full pre-adjustment turns.
- Return manifold complete with shut-off valves to accommodate thermo-electric actuators.
- End fittings composed of double radial end fitting and caps.
- Pair of mounting brackets.
- 1 1/4" M x 1" F reduction.

Series 663 IS

Pre-assembled distribution manifold for air-conditioning systems, complete with hot pre-formed insulation and 3 (from 3 to 13) outlets. Brass body. EPDM seals. Main connections 1 1/4" (1" with reduction as standard), F thread, centre distance 195 mm. Outlet connections 3/4" M - Ø 18, centre distance 50 mm. Medium water and glycol solutions. Max. percentage of glycol 30%. Maximum working pressure 10 bar. Working temperature range 5–100°C. Composed of:

- Flow manifold complete with lockshield valves that have 5 full pre-adjustment turns.
- Return manifold complete with shut-off valves to accommodate thermo-electric actuators.
- End fittings composed of double radial end fitting and caps.
- Pair of mounting brackets.
- 1 1/4" M x 1" F reduction.
- Hot pre-formed shell insulation made of closed cell expanded PE-X.

MANIFOLDS AND ACCESSORIES

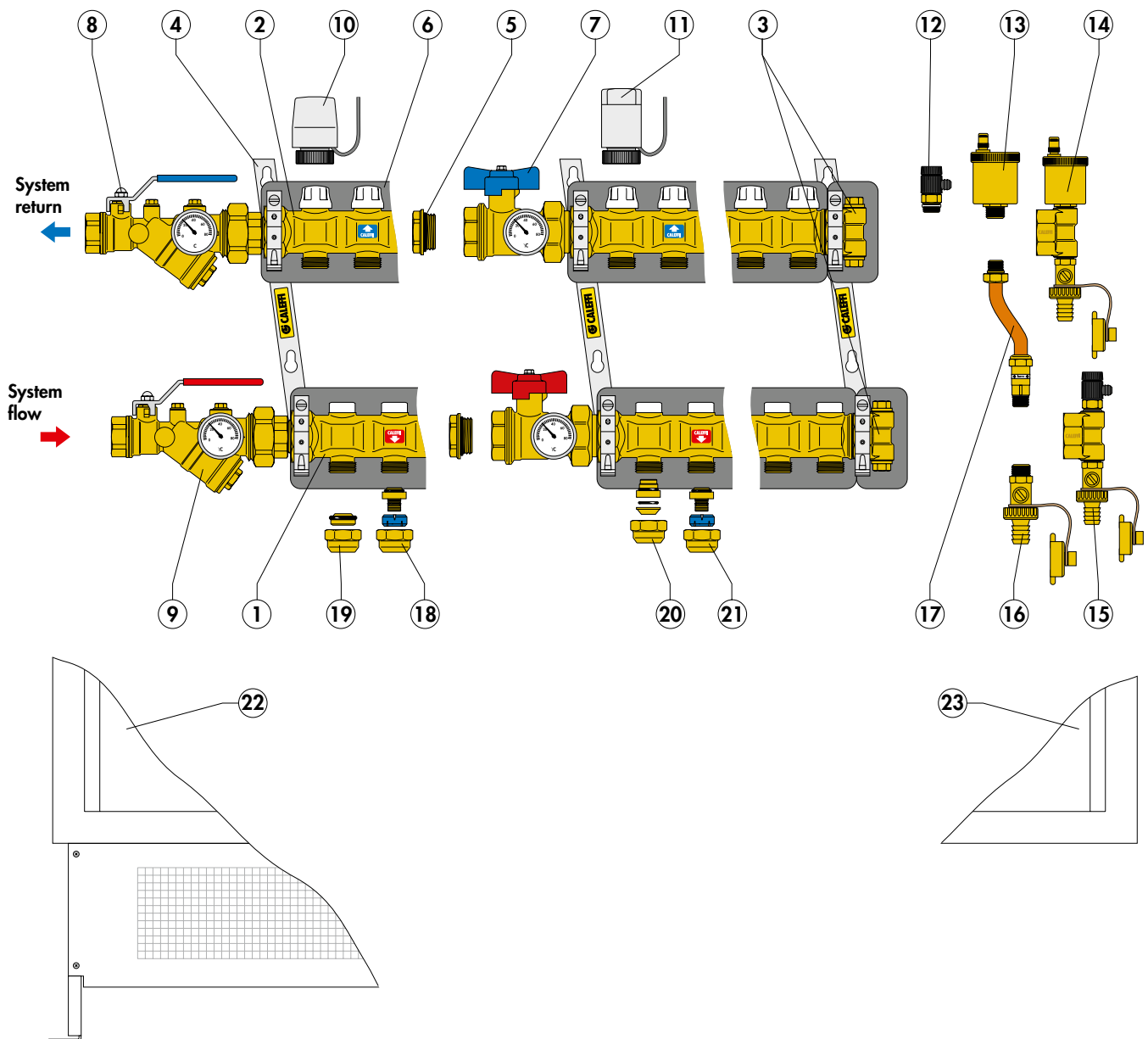

- | | |
|--|--|
| <p>1) Flow manifold complete with lockshield valves for flow rate pre-adjustment, 6631 series</p> <p>2) Return manifold complete with shut-off valves to accommodate thermo-electric actuators, 6630 series</p> <p>3) End fittings composed of double radial end fitting and caps, 5994 series</p> <p>4) Pair of brackets for box mounting, 658 series</p> <p>5) Reduction 1 1/4" M x 1" F, 3642 series</p> <p>6) Hot pre-formed shell insulation (version with insulation), 663 IS series</p> <p>7) Ball shut-off valves, 391 series</p> <p>8) AUTOFLOW®, 120 series</p> <p>9) Filter, 120 series</p> | <p>10) Thermo-electric actuator, 6561 series</p> <p>11) Thermo-electric actuator with manual opening and position indicator, 6563 series</p> <p>12) Manual air vent, code 337131</p> <p>13) Automatic air vent, code 502033</p> <p>14) End fitting with automatic air vent, code 599671</p> <p>15) End fitting with manual air vent, code 599672</p> <p>16) Drain cock, code 538400</p> <p>17) Off-centre by-pass kit, code 663000</p> <p>18) DARCAL union, 680 series</p> <p>19) Plug disc, 386 series</p> <p>20) Mechanical fitting, code 3475..</p> <p>21) DARCAL union, 679 series</p> <p>22) Box, code 661..5</p> <p>23) Box, code 659..4</p> |
|--|--|

By-pass eccentric kit with fixed setting, code 663000



Function

In heating and air-conditioning systems, the medium distribution circuits can be totally or partially shut off by closing the thermo-electric valves in the manifolds or the thermostatic valves of the radiators.

After reducing the flow rate, the differential pressure in the circuit may increase up to values which can result in noise, high medium speed, mechanical erosion and hydraulic unbalancing within the system.

The differential by-pass kit for 663 series manifolds serves to maintain the flow and return pressure of the manifold circuit balanced when the flow rate varies.

This valve is designed for quick coupling with 663 series manifolds, reducing the overall dimensions to a minimum.

Product range

Code 663000 Off-centre by-pass kit with fixed setting _____ sizes 3/8" x 1/2"

Technical specifications

Materials

Body:	brass EN 12164 CW614N
Nuts:	brass EN 12165 CW617N
Ø 18 gauged pipe with folder:	copper
Check valve obturator:	POM
Spring:	stainless steel
Seals:	EPDM
Seals:	asbestos-free fibre

Performance

Medium:	water, glycol solutions
Max. percentage of glycol:	30%
Maximum working pressure:	10 bar
Working temperature range:	-10–110°C
Fixed pressure setting:	20 kPa (2000 mm w.g.)
Flow manifold connection:	3/8" M
Return manifold connection:	1/2" M

Operating principle

The by-pass valve contains a check obturator integrated with a counter-acting spring.

When the fixed set pressure value is reached, the valve obturator opens gradually. In this way the flow rate is recirculated and, being proportional to the closure of the thermo-electric valves, keeps the differential pressure in the manifold circuit at a constant level.

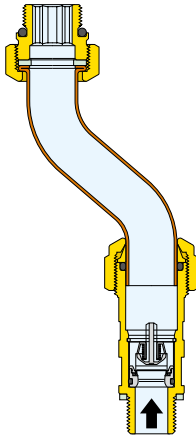

Construction details

Since the off-centre by-pass kit has no accessible adjustable devices, it has a fixed setting that cannot be changed.

The small, compact size and offset connections make this kit particularly easy to install, deciding to mount it after installing thermo-electric valves on the manifold. Furthermore, its installation does not require any wider or deeper zone boxes than those required for normal manifolds.

Dimensions

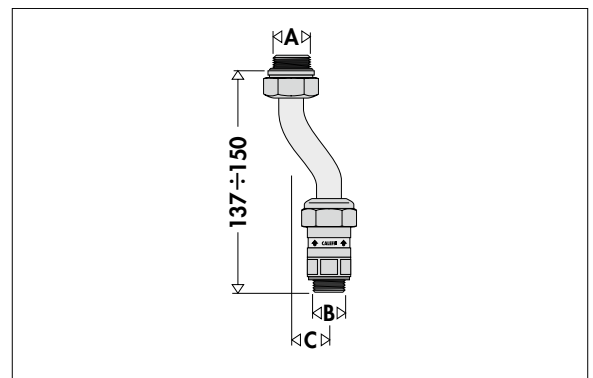

Code	A	B	C	Mass (kg)
663000	1/2	3/8	35	0,3

Hydraulic characteristics

By-pass differential pressure: 20 kPa (2000 mm w.g.)

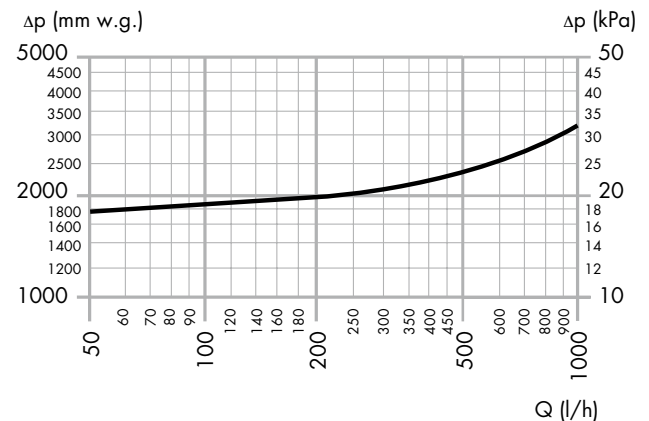

SPECIFICATION SUMMARY

Code 663000

Off-centre fixed setting by-pass kit. 3/8" M x 1/2" M threaded connections. Brass body and nuts. Gauged copper pipe. POM check valve obturator, stainless steel spring, EPDM seals, asbestos-free fibre seals. Medium water and glycol solutions. Max. percentage of glycol 30%. Maximum working pressure 10 bar. Working temperature range -10–110°C. Fixed pressure setting 20 kPa.

Thermo-electric actuators



6561

tech. broch. 01042

Thermo-electric actuator.
Normally closed.



Code	Voltage (V)	
656102	230	
656104	24	
656112	230	With auxiliary microswitch
656114	24	With auxiliary microswitch

Technical specifications

Materials

Protective shell: self-extinguishing polycarbonate
Colour: (code 656102/04) white RAL 9010
(code 656112/14) grey RAL 9002

Performance

Normally closed
Electric supply: 230 V (ac) - 24 V (ac) - 24 V (dc)
Starting current: ≤ 1 A
Running current: 230 V (ac) = 13 mA
24 V (ac) - 24 V (dc) = 140 mA
Running power consumption: 3 W
Auxiliary microswitch contact rating (code 656112/114): 0.8 A (230 V)
Protection class: IP 44 (in vertical position)
Double insulation construction: CE
Max. ambient temperature: 50°C
Operating time: opening and closing from 120 s to 180 s
Electric supply cable length: 80 cm

Thermo-electric actuators with manual opening knob and position indicator



6563

tech. broch. 01142

Thermo-electric actuator.
Normally closed.
PATENTED



Code	Voltage (V)	
656302	230	
656304	24	
656312	230	With auxiliary microswitch
656314	24	With auxiliary microswitch

Technical specifications

Materials

Protective shell: self-extinguishing polycarbonate
Colour: (code 656302/04) white RAL 9010
(code 656312/14) grey RAL 9002

Performance

Normally closed
Electric supply: 230 V (ac) - 24 V (ac) - 24 V (dc)
Starting current: ≤ 1 A
Running current: 230 V (ac) = 13 mA
24 V (ac) - 24 V (dc) = 140 mA
Running power consumption: 3 W
Auxiliary microswitch contact rating (code 656312/14): 0.8 A (230 V)
Protection class: IP 40
Double insulation construction: CE
Max. ambient temperature: 50°C
Operating time: opening and closing from 120 s to 180 s
Electric supply cable length: 80 cm

Thermo-electric actuator, quick-coupling installation with clip adaptor



6562/4

tech. broch. 01198

Thermo-electric actuator.
Normally closed.



Code	Voltage (V)	
656202	230	
656204	24	
656212	230	With auxiliary microswitch
656214	24	With auxiliary microswitch

Low power consumption version

Code	Voltage (V)	
656402	230	
656404	24	
656412	230	With auxiliary microswitch
656414	24	With auxiliary microswitch

Technical specifications

Materials

Protective shell: self-extinguishing polycarbonate
Colour: (code 656.02/04) white RAL 9010
(code 656.12/14) grey RAL 9002

Performance

Normally closed
Electric supply: 230 V (ac) - 24 V (ac) - 24 V (dc)
Starting current: (6562) ≤ 1 A, (6564) ≤ 250 mA
Running current: -6562 series: 230 V (ac) = 13 mA; 24 V (ac) - 24 V (dc) = 140 mA
-6564 series: 230 V (ac) = 15 mA; 24 V (ac) - 24 V (dc) = 125 mA
Running power consumption: 3 W
Auxiliary microswitch contact rating (code 656.12/14): 0.8 A (230 V)
Protection class (fitted in all positions): IP 54
Double insulation construction: CE
Operating time 6562 series
Operating time: opening and closing from 120 s to 180 s
Aux. microswitch closing time: from 120 s to 180 s
Operating time 6564 series
Opening time: (80%): 300 s; (100%): 600 s
Closing time: 240 s
Aux. microswitch closing time: 300 s
Electric supply cable length: 80 cm

Automatic flow rate regulators



Code		Flow rate m³/h
120961 1L2	1" F x 1 1/4" M	1.20
120961 1L4	1" F x 1 1/4" M	1.40
120961 1L6	1" F x 1 1/4" M	1.60
120961 1L8	1" F x 1 1/4" M	1.80
120961 2L0	1" F x 1 1/4" M	2.00
120961 2L2	1" F x 1 1/4" M	2.25
120961 2L5	1" F x 1 1/4" M	2.50

- They are available with other flow rates on request

120 AUTOFLOW®

tech. broch. 01041

Combination of automatic flow rate regulator and ball valve.

Factory set to automatically maintain the flow rate between ±5% of the established value.

Can be inspected, cleaned and the internal cartridge replaced without having to remove the valve body from the pipe.

Designed to accommodate pressure test ports for operation checks.

Fitted for connection to a drain pipe. The actuator stem of the ball valve has a retaining device and the closing lever is coated with vinyl. Reversible lever.

Male pipe union connections.

Code		Flow rate m³/h
120971 1L2	1 1/4" F x 1 1/4" M	1.20
120971 1L4	1 1/4" F x 1 1/4" M	1.40
120971 1L6	1 1/4" F x 1 1/4" M	1.60
120971 1L8	1 1/4" F x 1 1/4" M	1.80
120971 2L0	1 1/4" F x 1 1/4" M	2.00
120971 2L2	1 1/4" F x 1 1/4" M	2.25
120971 2L5	1 1/4" F x 1 1/4" M	2.50

Technical specifications

Temperature gauge scale: 0–80°C - Ø 40 mm
 Max. working pressure: 25 bar
 Max. working temperature: 110°C
 Δp range: 22–220 kPa
 Accuracy: ±5%



Code	
120961 000	1" F x 1 1/4" M

120 STRAINER

tech. broch. 01041

Combination of Y-strainer and ball valve.

Can be inspected, cleaned and the strainer replaced without having to remove the valve body from the pipe. Designed to accommodate pressure test ports for checking the strainer clogging level. Fitted for connection to a drain pipe, so that the strainer can be cleaned without being removed from the body.

The actuator stem of the ball valve has a retaining device and the closing lever is coated with vinyl. Reversible lever.

Male pipe union connections.

Code	
120971 000	1 1/4" F x 1 1/4" M

Technical specifications

Temperature gauge scale: 0–80°C - Ø 40 mm
 Max. working pressure: 25 bar
 Max. working temperature: 110°C
 Strainer mesh size Ø: 0.87 mm

Manifolds



6630

Return manifold complete with shut-off valve to accommodate a thermo-electric actuator.

Code	Connection	No. of outlets	Outlets
663030	1 1/4" F	x 3	3/4" M
663040	1 1/4" F	x 4	3/4" M
663050	1 1/4" F	x 5	3/4" M
663060	1 1/4" F	x 6	3/4" M
663070	1 1/4" F	x 7	3/4" M
663080	1 1/4" F	x 8	3/4" M

Technical specifications

Materials

Return manifold

Body: brass EN 1982 CB753S

Shut-off valve

Headwork: brass EN 12164 CW614N and PA
 Lockshield stem: stainless steel
 Obturator: EPDM
 Springs: stainless steel
 Seals: EPDM
 Knobs: ABS

Flow manifold

Body: brass EN 1982 CB753S

Lockshield valve

Headwork: brass EN 12164 CW614N
 Obturator stem: brass EN 12164 CW614N
 Seals: EPDM
 Cap: self-extinguishing polycarbonate

Maximum working pressure: 10 bar
 Working temperature range: 5–100°C

Main connections: 1 1/4" F x M
 Outlets: 3/4" M - Ø 18
 Outlet centre distance: 50 mm



6631

Flow manifold with lockshield valve.

Code	Connection	No. of outlets	Outlets
663130	1 1/4" F	x 3	3/4" M
663140	1 1/4" F	x 4	3/4" M
663150	1 1/4" F	x 5	3/4" M
663160	1 1/4" F	x 6	3/4" M
663170	1 1/4" F	x 7	3/4" M
663180	1 1/4" F	x 8	3/4" M

Shut-off valves

391



Pair of ball valves.
Female - male connections with union.
With 0-80°C temperature gauge scale, Ø 40 mm.
Max. working pressure: 10 bar.
Max. working temperature: 100°C.

Code		Kv (m³/h)
391167	1" x 1 1/4"	47,5
391177	1 1/4" x 1 1/4"	47,5

391



Pair of ball valves.
Female - male connections with union.
With temperature gauge connection.
Max. working pressure: 10 bar.
Max. working temperature: 100°C.

Code		Kv (m³/h)
391067	1" x 1 1/4"	47,5
3911077	1 1/4" x 1 1/4"	47,5

End fittings

5996



End fitting composed of 5994 series double radial end fitting with automatic air vent, code 502033, and 538 series drain cock.
Max. working pressure: 10 bar.
Max. drain pressure: 2,5 bar.
Max. working temperature: 110 °C.

Code	
599671	1 1/4"

5996



End fitting composed of 5994 series double radial end fitting with 337 series automatic air vent and 538 series drain cock.
Max. working pressure: 6 bar.
Max. working temperature: 85 °C.

Code	
599672	1 1/4"

Brackets



658

Pair of mounting brackets for use with 659 series boxes, or for direct wall mounting.
Complete with screws and wall anchors.

Code
658100

Air vent



5020

Automatic air vent.
In hot stamped brass.
With hygroscopic safety cap.
Max. working pressure: 10 bar.
Max. drain pressure: 2,5 bar.
Max. working temperature: 120°C.

Code
502033
3/8" M

337



Mini drain cock.
Adjustable drain.
PTFE seal on thread.
Max. working pressure: 6 bar.
Max. working temperature: 85°C.
Medium: water, glycol solutions.
Max. percentage of glycol: 30%.



Code
337131
3/8" M

Drain cock



538

Drain cock with hose connection and cap.
Max. working pressure: 10 bar.
Max. working temperature: 110 °C.

Code
538400
1/2" M

Fittings



680 DARGAL

Self-adjustable diameter fitting for single and multi-layer plastic pipes.
 Max. working pressure: 10 bar.
 Working temperature range:
 5–80°C (PE-X)
 5–75°C (Multi-layer marked 95°C).

Code	3/4"	Ø _{internal}	Ø _{outside}
680507	7,5– 8	10,5–12	
680502	7,5– 8	12	-14
680503	8,5– 9	12	-14
680500	9 – 9,5	14	-16
680501	9,5–10	12	-14
680506	9,5–10	14	-16
680515	10,5–11	14	-16
680517	10,5–11	16	-18
680524	11,5–12	14	-16
680526	11,5–12	16	-18
680535	12,5–13	16	-18
680537	12,5–13	18	-20
680544	13,5–14	16	-18
680546	13,5–14	18	-20
680555	14,5–15	18	-20
680556	15 – 15,5	18	-20
680564	15,5–16	18	-20
680505	17	22,5	



347

Compression fitting for copper pipe with O-ring seal.
 Max. working pressure: 10 bar.
 Working temperature range: -25–120°C.

Code	3/4" - Ø
347510	10
347512	12
347514	14
347515	15
347516	16
347518	18



386

Screw plug with nut, for manifold outlets.

Code	3/4"
386500	



679 DARGAL

Fitting for multi-layer pipe with continuous high-temperature operation.
 Max. working pressure: 10 bar.
 Working temperature range: 0–95°C.
 Chrome plated.

To use these new fittings correctly, the multi-layer pipe must be calibrated with a Caleffi 679 series gauge before use.

Code	3/4" - Ø
679514	14x2
679524	16x2
679525	16x2,25
679544	18x2
679564	20x2
679565	20x2,25
679566	20x2,5



679

Gauge and grip for calibrating multi-layer pipes before use with 679 series fittings.

Code	Description
679001	Gauge Ø 14x2
679002	Gauge Ø 16x2
679003	Gauge Ø 16x2,25
679004	Gauge Ø 18x2
679006	Gauge Ø 20x2
679007	Gauge Ø 20x2,25
679008	Gauge Ø 20x2,5
679009	"Burnished" effect grip for gauge

Calibration of the multi-layer pipe and assembly of the union components, 679 series

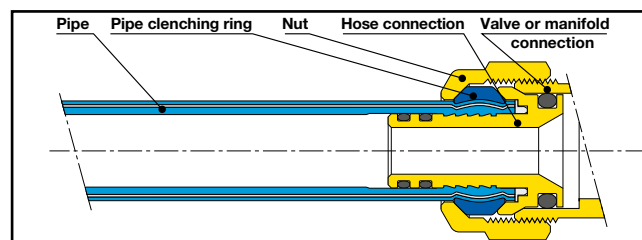
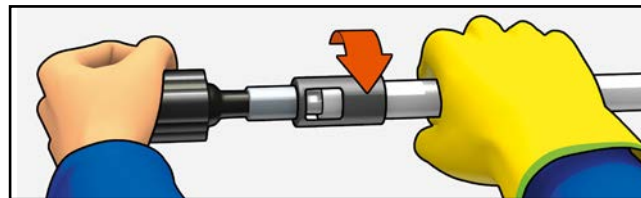

Choice of box size, 659 or 661 series, according to the number of outlets

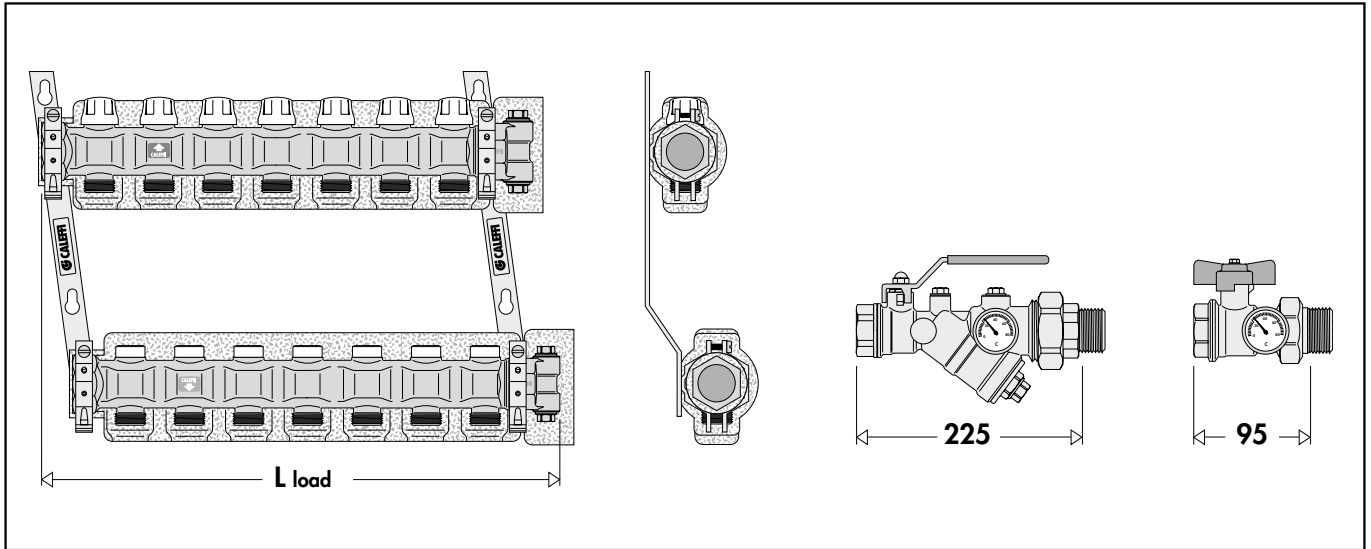

Code without insulation	6637C5	6637D5	6637E5	6637F5	6637G5	6637H5	6637I5	6637L5	6637M5	6637N5	6637O5
Code with insulation	6637C5 IS	6637D5 IS	6637E5 IS	6637F5 IS	6637G5 IS	6637H5 IS	6637I5 IS	6637L5 IS	6637M5 IS	6637N5 IS	6637O5 IS
No. outlets	3	4	5	6	7	8	9	10	11	12	13
Manifold total length (mm)	220	270	320	370	420	470	550	600	650	700	750
Box length (mm)	400	400	600	600	600	800	800	800	800	1000	1000
Box code, 659 series	659044	659044	659064	659064	659064	659084	659084	659084	659084	659104	659104
Box code, 661 series	661045	661045	661065	661065	661065	661085	661085	661085	661085	661105	661105

Boxes



659

Box for 663 series manifolds.
Wall or floor installation
(with 660 series).
Closure with a push-fit clamp.
Made of painted sheet steel.
Depth adjustable
from 110 to 140 mm.

Code	(h x w x d)
659044	500 x 400 x 110-140
659064	500 x 600 x 110-140
659084	500 x 800 x 110-140
659104	500 x 1000 x 110-140
659124	500 x 1200 x 110-140



661

Box for 663 series manifolds.
Closure with a push-fit clamp.
Made of painted sheet metal
Depth adjustable
from 110 to 150 mm.
Complete with supports for
floor installation.
Height adjustable
from 270 to 410 mm.

Code	(h x w x d)
661045	500 x 400 x 110-150
661065	500 x 600 x 110-150
661085	500 x 800 x 110-150
661105	500 x 1000 x 110-150
661125	500 x 1200 x 110-150



660

Floor installation KIT
for 659 series box.
Consisting of:
- 2 mounts, height (cm) 20,
- 2 side panels,
- 1 pipe-bending bar.

Code	
660040	for 659044
660060	for 659064
660080	for 659084
660100	for 659104
660120	for 659124

Application diagrams

Independent radiator system with wall-mounted boiler and direct distribution

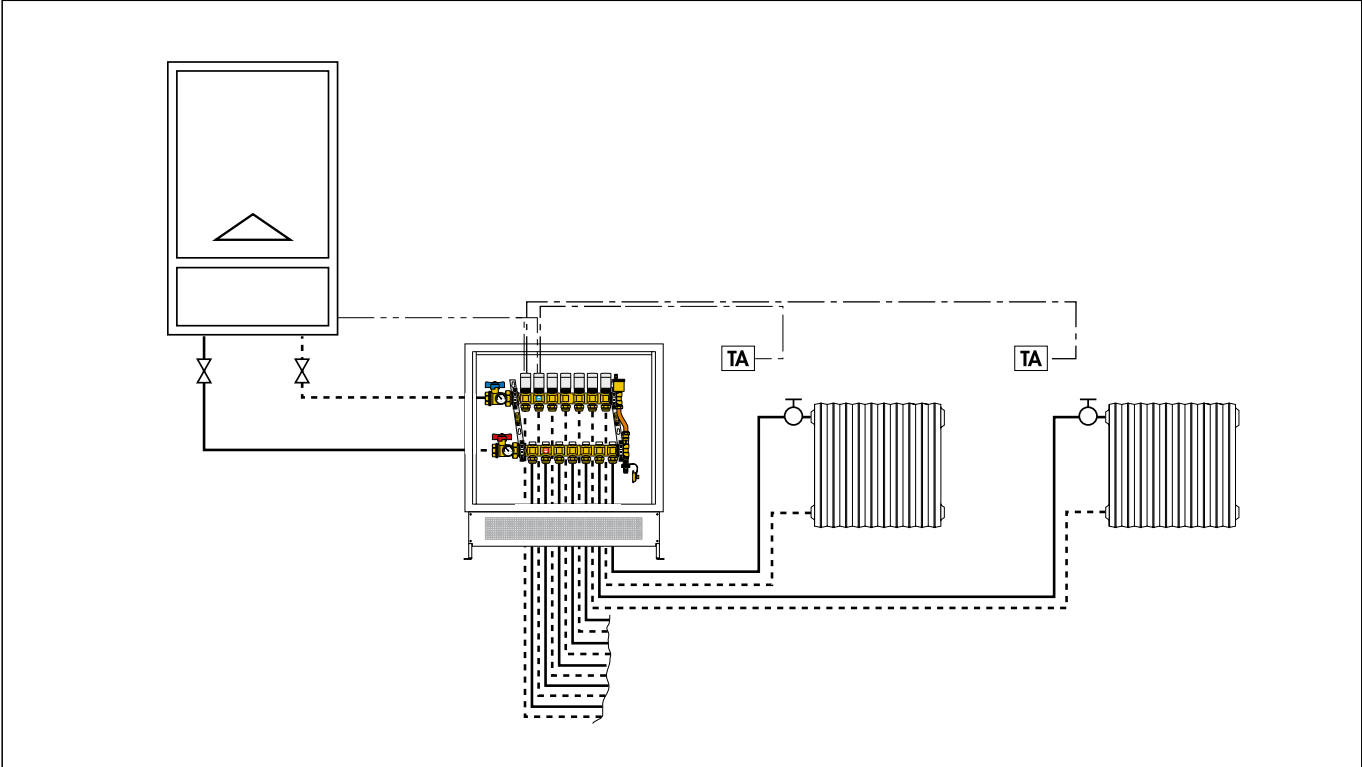

Heating and air-conditioning system with two-pipe fan-coils

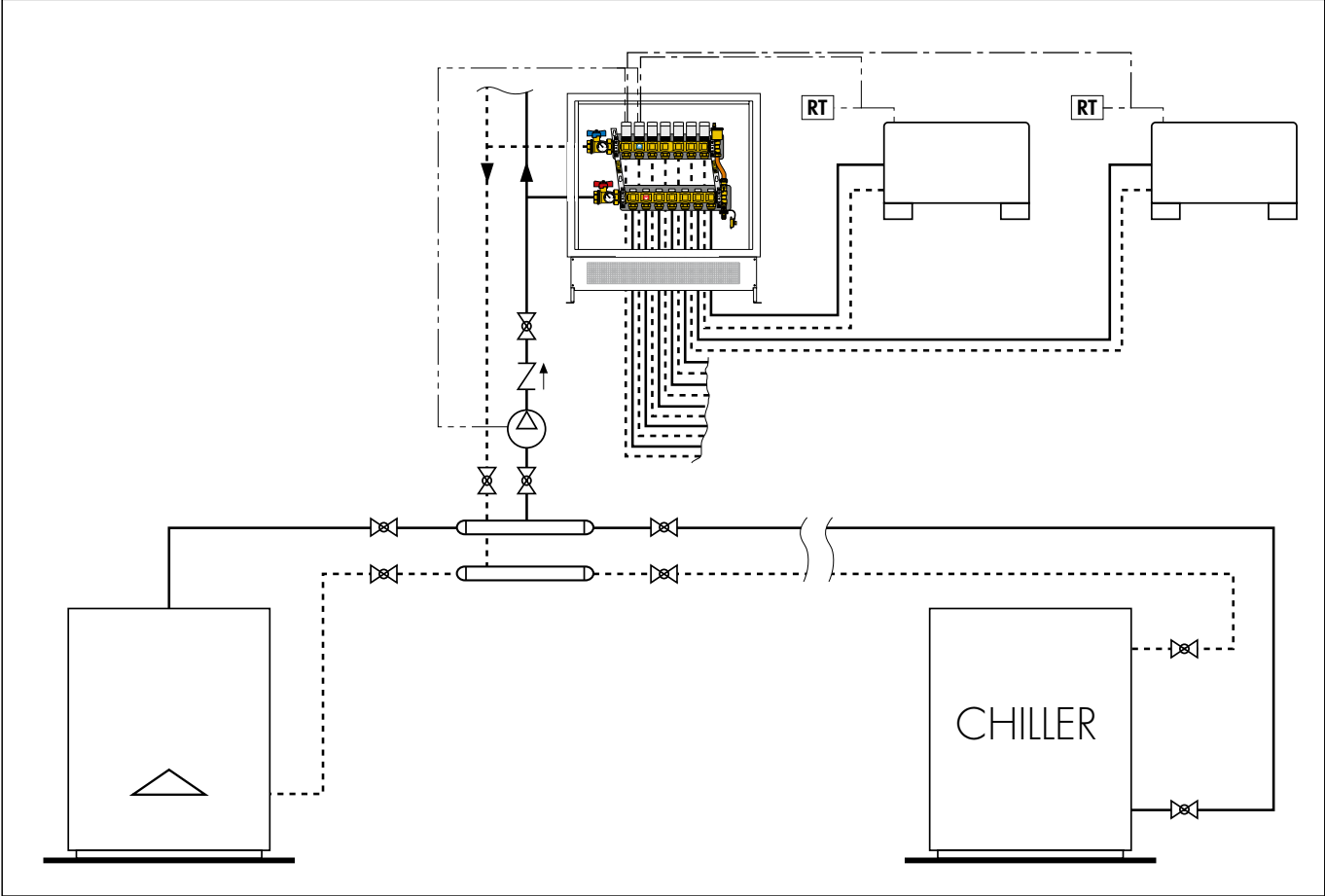

We reserve the right to make changes and improvements to the products and related data in this publication, at any time and without prior notice.



Caleffi S.p.A.
S.R. 229, no. 25 · 28010 Fontaneto d'Agogna (NO) - Italy
Tel. +39 0322 8491 · Fax +39 0322 863723
info@caleffi.com · www.caleffi.com
© Copyright 2018 Caleffi